

HELIKA[®]
Inspired by slow living





INSPIRED BY SLOW LIVING

HELIKA® is a new and innovative brand that launched in 2023, replacing the AQUASANITA brand, a long-standing and reliable manufacturer of granite sinks in Lithuania. The name **HELIKA®** comes from the Esperanto word for snail, symbolising the durability and quality of our artificial granite products. Our unique SILICSANA formula ensures that our granite sinks maintain their appearance and performance, even under the most demanding conditions. That is why we provide a 15-year guarantee for all our granite sinks. With the **HELIKA®** brand, we offer you everything you need for your kitchen sink area. We have a wide range of kitchen faucets, steel sinks, and accessories that suit different design and colour preferences. Whether you are looking for a modern, classic, or rustic style, we have the perfect solution for you. We are also proud of our other brand, **TURTL®**, which offers bathroom washbasins and faucets that perfectly combine functionality and aesthetics.

HELIKA® yra naujas prekių ženklas, kuris 2023 metais pakeitė AQUASANITA – ilgametį ir patikimą granitinių plautuvių gamintoją Lietuvoje. **HELIKA®** esperanto kalboje reiškia sraigę ir simbolizuoja mūsų dirbtinio granito produktų ilgaamžiškumą bei kokybę. Mūsų unikali SILICSANA dirbtinio granito formulė užtikrina nekintančią plautuvių išvaizdą, tad visoms granitinėms plautuvėms drąsiai suteikiame 15 metų garantiją. **HELIKA®** prekių ženklu mes siekiame pasiūlyti jums viską, ko reikia patogiai virtuvės plautuvės zonai. Turime platų asortimentą virtuvės maišytuvų, plautuvių ir aksesuarų, kurie atitinka skirtingus dizaino ir spalvų poreikius. Taip pat didžiuojamės savo kitu prekių ženklu – **TURTL®**, kuris siūlo vonios kambario praustuvus ir maišytuvus. Šiuose produktuose puikiai dera funkcionalumas ir estetika.

HELIKA® ist eine neue und innovative Marke, die im Jahr 2023 eingeführt wurde und AQUASANITA ablöst, einen langjährigen und zuverlässigen Hersteller von Granitspülen in Litauen. Der Name **HELIKA®** leitet sich vom Esperanto-Wort für Schnecke ab und symbolisiert die Langlebigkeit und Qualität unserer Kunstgranitprodukte. Unsere einzigartige SILICSANA-Formel sorgt dafür, dass unsere Granitspülen auch unter den anspruchsvollsten Bedingungen ihr Aussehen und ihre Eigenschaften behalten. Deshalb gewähren wir 15 Jahre Garantie auf alle unsere Granitspülen. Mit der Marke **HELIKA®** bieten wir Ihnen alles, was Sie für Ihren Spülbereich in der Küche benötigen. Wir haben eine große Auswahl an Küchenarmaturen, Stahlspülen und Zubehör, die zu verschiedenen Design- und Farbvorlieben passen. Ob Sie nun einen modernen, klassischen oder rustikalen Stil bevorzugen – wir haben die perfekte Lösung für Sie. Wir sind auch stolz auf unsere andere Marke, **TURTL®**, die Waschtische und Armaturen für Badezimmer anbietet, die Funktionalität und Ästhetik perfekt vereinen.

OUR PHILOSOPHY

MŪSŲ FILOSOFIJA / UNSERE PHILOSOPHIE

The inspiration for **HELIKA®** and **TURTL®** comes from two of the most fascinating creatures of nature and water: the snail and the turtle. These two animals embody the idea of living life at a slower pace, appreciating the simple pleasures in life and being in harmony with nature. The philosophy of slow living is firmly in place and encourages a mindful and calm approach to daily life. Our passion is to find the best shapes and materials for our granite sinks/washbasins, stainless steel sinks, modern-style faucets, and accessories, as well as to stay innovative and create products that offer value and satisfaction. Slow living is more than just a philosophy; it is a way of life that focuses on balance, simplicity and meaningfulness. We know that modern life can be fast-paced and stressful, but we believe that taking the time to enjoy life's little pleasures is important to one's well-being. The company's products are designed to support a decelerated lifestyle and create a warm and nurturing atmosphere in the kitchen and bathroom areas.

HELIKA® ir **TURTL®** prekių ženklus įkvėpė gyvūnai: sraigė ir vėžlys. Jie simbolizuoja idėją gyventi lėtesniu tempu, vertinant paprastus gyvenimo malonumus, išlaikant harmoniją su gamta. **Slow living** filosofija skatina dėmesingą bei ramų požiūrį į kasdienį gyvenimą. Mūsų pagrindinė siekiama – rasti geriausias formas ir medžiagas granitinėms plautuvėms / praustuvams, nerūdijančio plieno plautuvėms, asortimente turėti naujausių tendencijų maišytuvų ir plautuvių priedų, išlikti inovatyvių sprendimų virtuvėje kūrėjais. **Slow living** yra daugiau nei filosofija, tai gyvenimo būdas, orientuotas į pusiausvyrą, harmoniją ir mėgavimąsi paprastais dalykais. Žinome, kad šiuolaikinis gyvenimas yra greitas, įtemptas, tačiau namų, virtuvės aplinka yra mūsų kasdienybės pamatas, čia mes pradedame ir baigiame kiekvieną dieną, rūpinamės savimi ir savo artimaisiais. Patikimi **HELIKA®** produktai padės sukurti šiltą bei puoselėjančią atmosferą jūsų namuose.

Die Inspiration für die Namen **HELIKA®** und **TURTL®** stammt von zwei der faszinierendsten Geschöpfe des Wassers und der Natur: der Schnecke und der Schildkröte. Diese beiden Tiere verkörpern die Idee, das Leben langsamer anzugehen, die einfachen Freuden des Lebens zu schätzen und im Einklang mit der Natur zu leben. Die Philosophie des Slow Living ist bei uns fest verankert und ermutigt zu einer achtsamen und in-sich-ruhenden Haltung im Alltag. Unsere Leidenschaft ist die Suche nach den besten Formen und Materialien für Granitspülen/Waschbecken, Edelstahlspülen, sowie moderne Armaturen und Accessoires. Dabei versuchen wir stets, innovativ zu bleiben und Produkte zu schaffen, die wertig sind und unsere Kunden begeistern. Slow Living ist mehr als nur eine Idee; es ist eine Lebensweise die sich auf Ausgewogenheit, Einfachheit und Sinnhaftigkeit konzentriert. Wir wissen, dass das moderne Leben schnelllebig und stressig sein kann. Aber wir glauben auch, dass es wichtig ist, sich Zeit für die kleinen Freuden des Lebens Zeit zu nehmen. Die Produkte unseres Unternehmens sind so konzipiert, dass sie einen entschleunigten Lebensstil unterstützen und eine warme und gepflegte Atmosphäre in Küche und Bad schaffen.

CONTENTS TURINYS / INHALT

CONTENTS / TURINYS / INHALT	5
HELIKA EXPORT / EKSPORTO ŠALYS / EXPORTLÄNDER	6
BALANCED SUSTAINABILITY / DARNUS TVARUMAS / AUSGEGLICHENE NACHHALTIGKEIT	8
PRODUCTION / GAMYBA / DIE HERSTELLUNG	10
SILICSANA® – THE ULTIMATE MATERIAL / SILICSANA® – GERIAUSIA MEDŽIAGA / SILICSANA® – DAS ULTIMATIVE MATERIAL	12
GRANITE SINKS / DIRBTINIO GRANITO PLAUTUVĖS / GRANITSPÜLEN	14
TESA	18
TESA PLUS	22
QUADRO	24
DELICIA	28
DELICIAPLIUS	30
ECO	32
SIMPLEX	36
ONDO	36
NOVA	37
NOTUS	38
CLARUS	40
KOPA NEW	42
MAGNA	45
LIRA	46
BELLA	48
PAPILLON	49
ARCA	50
LARGUS NEW	55
VILLA PREMIUM	56
DIAMANTO NEW	57
STAINLESS STEEL SINKS / NERŪDIJANČIO PLIENO PLAUTUVĖS / EDELSTAHLSPÜLEN	58
TERRA	62
NOVA	64
AIRA	66
DERA	68
ENNA	70
LUNA	73
FAUCETS / MAIŠYTUVAI / ARMATUREN	80
ACCESSORIES / AKSESUARAI / ZUBEHÖR	98
TURTL® CAST MARBLE WASHBASINS / TURTL® GELKAUTO PRAUSTUVAI / TURTL® WASCHBECKEN AUS MINERALGUSS	120

HELIKA EXPORT EKSPORTO ŠALYS / EXPORTLÄNDER

All products are poised for dispatch from the 8000-square-metre warehouse facility in Lithuania. The company is equipped to provide various packaging alternatives tailored to client specifications, including standard boxes and cost-effective cardboard packaging. This ensures secure delivery of goods across the globe, catering to over 50 countries.

Visi gaminiai paruošiami eksportui 8000 kv. m. sandėlio patalpose Lietuvoje. Įmonė yra pasirengusi teikti įvairias pakavimo, pristatymo alternatyvas pagal kliento specifikacijas, įskaitant ypač saugias, ekologiškas ar ekonomiškias pakuotes. Tai užtikrina saugų prekių pristatymą net į 50 šalių.



Alle Produkte werden in unserem 8000 Quadratmeter großen Werk in Litauen hergestellt und für den Versand vorbereitet. Das Unternehmen ist in der Lage, verschiedene, auf die Kundenspezifikationen zugeschnittene Verpackungsalternativen anzubieten, darunter Standardkartons und kostengünstige Kartonverpackungen. Dies gewährleistet eine sichere Lieferung von Waren auf der ganzen Welt und beliefert über 50 Länder.

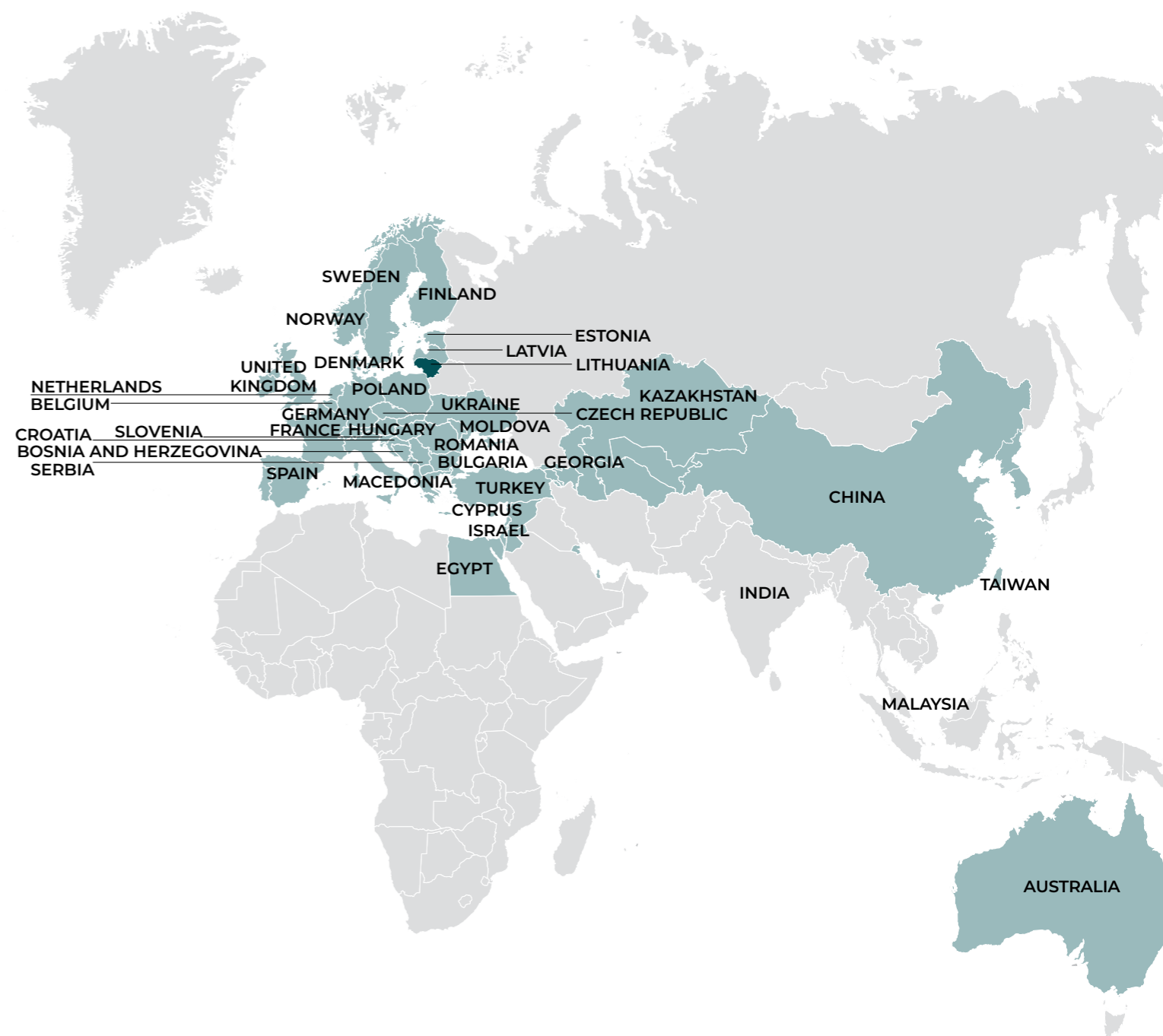

BALANCED SUSTAINABILITY

DARNUS TVARUMAS / AUSGEGLICHENE NACHHALTIGKEIT

- **Environmental Stewardship:** By 2025, we'll be aligned with the global rhythm of sustainability by adopting the ISO 14001 standard for environmental management systems (EMS).
 - **Life Cycle Assessment:** In the 2024 environmental product declaration (EPD), we state our transparency in communicating the environmental performance and impact of our granite sinks over their lifetime.
 - **Digital Harmony:** We are transitioning our printed instructions to an online space, where you can easily access **HELIKA**® Sinks installation and maintenance information. This shift is not just about going digital; it's about reducing our footprint and saving an impressive 250 trees each year!
 - **Sustainable Packaging:** Every package is made of recycled 5-layer cardboard, reflecting our commitment to reuse and reduce.
 - **Recycled Accessories:** The accessories we offer, like strainers or siphons, are made from recycled plastic, giving new life to what was once discarded.
 - **Circular Economy:** When a sink doesn't meet our standards, we shred and transform it into material for roads, paving the way for a greener future.
- In everything we do, we're mindful of the place and impact, choosing a path that's kinder to our planet and aligned with the slow living movement's serene stride.

- **Atsakomybė už aplinką:** iki 2025 m. prisitaikysime prie pasaulinio tvarumo ritmo ir įdiegsime ISO 14001 standartą aplinkosaugos vadybos sistemoms (AVS).
 - **Produkto gyvavimo ciklo vertinimas:** nuo 2024 metų vidurio skaidriai deklaruojame mūsų gaminių plautuvių poveikį aplinkai, įvertindami produkto gyvavimo ciklą. Tai įrodo mūsų tarptautinei rinkai skirta EPD deklaracija.
 - **Skaitmeninė darna:** popierines instrukcijas perkeliame į internetinę erdvę, kurioje lengvai rasite **HELIKA**® plautuvių montavimo ir priežiūros informaciją. Šis pokytis susijęs ne tik su skaitmeninimu, bet ir su ekologinio pėdsako mažinimu bei 250 medžių išsaugojimu kasmet!
 - **Tvari pakuotė:** kiekviena plautuvės kartoninė dėžė pagaminta iš perdirbto 5 colių kartono, o tai atspindi įsipareigojimą antriniam panaudojimui ir atliekų mažinimui.
 - **Perdirbti priedai:** mūsų siūlomi plautuvių priedai, pavyzdžiui, ventiliai ar sifonai, gaminami iš perdirbto plastiko, taip suteikiant naują gyvenimą tam, kas anksčiau buvo panaudota ir išmesta.
 - **Žiedinė ekonomika:** jei pagaminta produkcija neatitinka mūsų standartų, mes ją susmulkiname ir paverčiame medžiaga kelio dangai, taip nutiesdami kelią ekologiškesnei ateičiai.
- Atlikdami kiekvieną veiksmą atsižvelgiame į tempą, poveikį gamtai ir pasirenkame kelią, kuris yra draugiškesnis mūsų planetai, atitinka SLOW LIVING filosofiją.

- **Verantwortung für die Umwelt:** Bis 2025 werden wir uns dem globalen Rhythmus der Nachhaltigkeit anpassen, indem wir die ISO-Norm 14001 für Umweltmanagementsysteme (EMS) einführen.
 - **Lebenszyklusanalyse:** Mit dem Erwerb der EPD (Umweltproduktdeklaration) im Jahr 2024 erklären wir unsere Transparenz bei der Kommunikation der Umweltleistung und -auswirkungen unserer Granitspülen während ihrer Lebensdauer.
 - **Digitale Harmonie:** Wir stellen unsere gedruckten Anleitungen auf einen Online-Bereich um, in dem Sie leicht auf die Installations- und Wartungsinformationen von **HELIKA**® Sinks zugreifen können. Bei dieser Umstellung geht es nicht nur um die Digitalisierung, sondern auch darum, unseren ökologischen Fußabdruck zu verringern und jedes Jahr 250 Bäume zu retten!
 - **Nachhaltige Verpackung:** Jede Verpackung besteht aus recyceltem 5-Zoll-Karton und spiegelt unser Engagement für Wiederverwendung und Reduzierung wider.
 - **Recyceltes Zubehör:** Das von uns angebotene Zubehör, wie Siebe oder Siphons, wird aus recyceltem Kunststoff hergestellt und gibt dem, was einst weggeworfen wurde, neues Leben.
 - **Kreislaufwirtschaft:** Wenn ein Waschbecken nicht unseren Standards entspricht, schreddern wir es und verwandeln es in Material für Straßen und ebnen so den Weg für eine grünere Zukunft.
- Bei jeder Handlung achten wir auf das Tempo und die Auswirkungen und wählen einen Weg, der schonender für unseren Planeten ist und mit der ruhigen Gangart der Slow-Living-Bewegung übereinstimmt.



BIRŠTONAS, LITHUANIA. PHOTOGRAPHER: MARIUS MORKUNAS



PRODUCTION

GAMYBA / DIE HERSTELLUNG

All the lines are designed by our R&D team who cover the full process of production:

- Filler preparation
- Sand preparation
- Resin preparation
- Component mixers
- Mould production
- Moulding line
- Proving line
- Testing in our own laboratory according to standards:
EN 13310:2015+A1:2018 (Sinks)
EN 14688:2015+A1:2018 (Washbasins)
- Packaging and warehousing.

Visos linijos yra sukurtos mūsų MTEP komandos ir apima visą gamybos procesą:

- Kompozicinio mišinio paruošimas;
- Smėlio paruošimas;
- Dervos paruošimas;
- Komponentiniai junginiai;
- Formų gamyba;
- Liejimo linija;
- Produktų kokybės skyrius;
- Testavimas laboratorijoje pagal standartus:
EN 13310:2015+A1:2018 (plautuvės),
EN 14688:2015+A1:2018 (praustuvai);
- Pakavimas ir sandėliavimas.

Alle Linien werden von unserer Forschung und Entwicklung entworfen und decken den gesamten Produktionsprozess ab:

- Vorbereitung des Füllstoffs
- Sandvorbereitung
- Harzvorbereitung
- Komponentenmischer
- Herstellung von Formen
- Formanlage
- Prüflinie
- Tests in unserem eigenen Labor nach Norm:
EN 13310:2015+A1:2018 (Küchenspülen)
EN 14688:2015+A1:2018 (Waschtische)
- Verpackung und Lagerung.



SILICSANA® the ultimate material

SILICSANA® – GERIAUSIA MEDŽIAGA /
SILICSANA® – DAS ULTIMATIVE MATERIAL

SILICSANA® granite composite is made up of **80 %** natural **quartz** – a mineral with exceptional hardness features – and a sand-based material.

HELIKA® kitchen sinks are designed to deliver **superior performance** and durability, even under the most demanding conditions.

SILICSANA® granito kompozitas sudarytas iš **80 %** natūralaus **kvarco** – vieno atspariausių mineralų žemėje – ir smėlio pagrindu sukurtos medžiagos.

HELIKA® virtuvės plautuvės – garantuoja **ilgaamžiškumą ir kokybę** net pačiomis sudėtingiausiomis sąlygomis.

Der Granitverbundwerkstoff **SILICSANA®** besteht zu **80 %** aus natürlichem **Quarz** – einem Mineral mit außergewöhnlichen Härteeigenschaften – und einem sandbasierten Material.

HELIKA® – Küchenspülen sind so konzipiert, dass sie selbst unter anspruchsvollsten Bedingungen überragende Leistung und Haltbarkeit bieten.



SILICSANA®

ADVANTAGES
PRIVALUMAI / VORTEILE:



THERMAL RESISTANCE
ATSPARUMAS KARŠČIUI
HITZEBESTÄNDIGKEIT



STAIN RESISTANCE
ATSPARUMAS DĖMĖMS
RESISTENZ GEGEN FLECKEN



**TOLERANCE TO FLUCTUATIONS
IN WATER TEMPERATURE**
TOLERANCIJA VANDENS
TEMPERATŪROS SVYRAVIMAMS
TOLERANZ GEGENÜBER
SCHWANKUNGEN DER
WASSESTEMPERATUR



ABRASION RESISTANCE
ATSPARUMAS ĮBRĖŽIMAMS
KRATZFESTIGKEIT



COLOUR STABILITY
SPALVOS STABILUMAS
FARBSTABILITÄT



IMPACT EFFECT RESISTANCE
ATSPARUMAS SMŪGIAMS
SCHLAGFESTIGKEIT



15-year
warranty



Made
in EU



Tested by
EN 13310:2015



1935/2004/EC
10/2011/EU



DGCCRF



ISO
9001

COMPOSITE GRANITE SINKS

DIRBTINIO GRANITO PLAUTUVĖS /
GRANITSPÜLEN

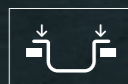

TOPMOUNTED
MONTUOJAMA ANT STALVIRŠIO
EINBAU

TESA
TESA PLUS
QUADRO
DELICIA PLUS
ECO
SIMPLEX
ONDO
NOVA
NOTUS
CLARUS
KOPA NEW
MAGNA
LIRA
BELLA
PAPILLON
LARGUS NEW
DIAMANTO NEW



UNDERMOUNTED
MONTUOJAMA PO STALVIRŠIU
UNTERBAU

DELICIA
ARCA
VILLA PREMIUM



COLOURS SPALVOS / FARBEN

Silicsana granite surface

Silicsana granito paviršius / Oberfläche aus Silicsana-Granit



COMPOSITE GRANITE SINKS

SYMBOLS / SIMBOLIAI / SYMBOLE



Mounting type: Topmounted
Montavimo tipas: ant stalviršio
Einbauart: Einbau



Partially drilled holes
Iš dalies gręžtos skylės
Teilweise gebohrte Löcher



Mounting type: Undermounted
Montavimo tipas: po stalviršiu
Einbauart: Unterbau



Round overflow
Apvalus persipylimas
Runder Überlauf

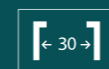

Cabinet size: 30 cm
Spintelės plotis: 30 cm
Schrankgröße: 30 cm



Rectangular overflow
Stačiakampis persipylimas
Rechteckiger Überlauf

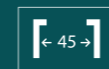

Cabinet size: 45 cm
Spintelės plotis: 45 cm
Schrankgröße: 45 cm



Square overflow
Kvadrato formos persipylimas
Quadratischer Überlauf



Cabinet size: 50 cm
Spintelės plotis: 50 cm
Schrankgröße: 50 cm



Round hollow overflow
Apvalus persipylimas su skylutėmis
Runder Überlauf mit Löchern

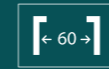

Cabinet size: 60 cm
Spintelės plotis: 60 cm
Schrankgröße: 60 cm



Big bowl
Didelis dubuo
Großes Becken

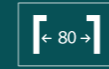

Cabinet size: 80 cm
Spintelės plotis: 80 cm
Schrankgröße: 80 cm



Tempered glass thickness: 8 mm
Grūdinto stiklo storis: 8 mm
Dicke des gehärteten Glases: 8 mm



Reversible: Left/right
Apsukama: kairė/dešinė
Zweiseitig: Links/rechts



15-year warranty
15 metų garantija
15 Jahre Garantie



Manual basket strainer
Ventilis, uždaromas ranka
Manueller Siebkorb



Pop-up basket strainer
Automatinis ventilis, pasukant rankenėlę
Siebkorb mit Drehknopf



Push-button strainer
Automatinis ventilis, paspaudžiant rankenėlę
Siebkorb mit Druckknopf



Factory-made holes (1 hole)
Gamyklinės skylės (1 skylė)
Vom Werk vorgefertigte Löcher (1 Loch)



Factory-made holes (2 holes)
Gamyklinės skylės (2 skylės)
Vom Werk vorgefertigte Löcher (2 Löcher)



Factory-made holes (3 holes)
Gamyklinės skylės (3 skylės)
Vom Werk vorgefertigte Löcher (3 Löcher)



TESA SQT102

Topmounted
Iš viršaus
Einbau

Installation type
Montavimo būdas
Einbauart

620 x 500 mm

Sink dimensions
Plautuvės matmenys
Abmessungen der Spüle

345 x 436 x 200 mm

Bowl dimensions
Dubens matmenys
Abmessungen des Beckens

500 mm

Min. cabinet size
Minimalus spintelės plotis
Min. Schrankgröße

Supplied with
Komplekte
Enthalten

AQL-002V (AWP) or / arba / oder
AQF-002V (AW)

Recommended accessories
Rekomenduojami aksesuarai
Empfohlenes Zubehör

110 111 113 114 202 220 222 601 710

50

50

TESA SQT100

Topmounted
Iš viršaus
Einbau

Installation type
Montavimo būdas
Einbauart

490 x 510 mm

Sink dimensions
Plautuvės matmenys
Abmessungen der Spüle

425 x 365 x 200 mm

Bowl dimensions
Dubens matmenys
Abmessungen des Beckens

500 mm

Min. cabinet size
Minimalus spintelės plotis
Min. Schrankgröße

Supplied with
Komplekte
Enthalten

AQF-001V (W) or / arba / oder
AQF-002V (AW) or / arba / oder
AQL-002V (AWP)

Recommended accessories
Rekomenduojami aksesuarai
Empfohlenes Zubehör

110 111 113 114 202 220 222 601 710

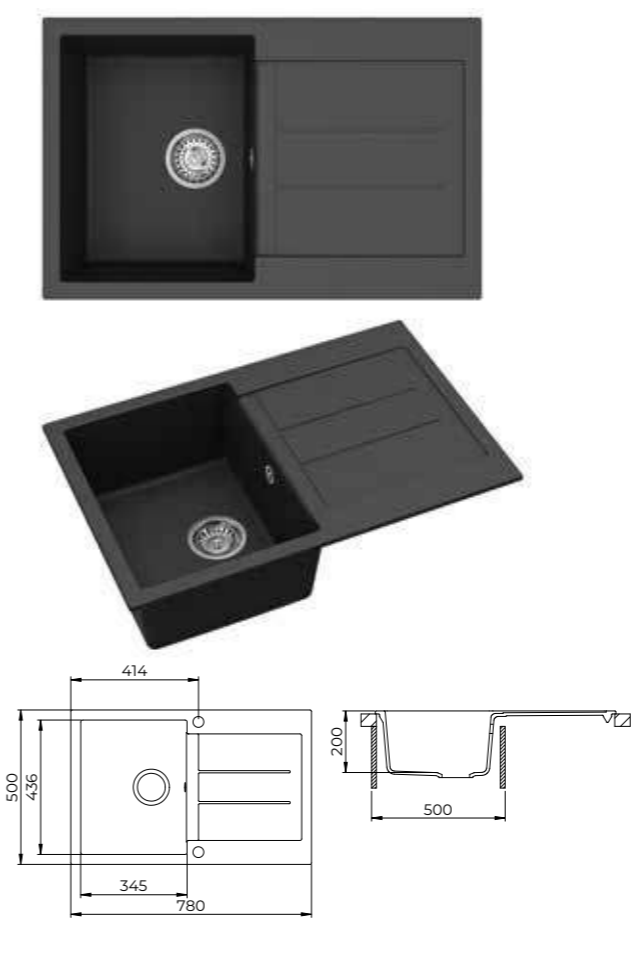

TESA SQT101

Topmounted
Iš viršaus
Einbau

Installation type
Montavimo būdas
Einbauart

780 x 500 mm

Sink dimensions
Plautuvės matmenys
Abmessungen der Spüle

345 x 436 x 200 mm

Bowl dimensions
Dubens matmenys
Abmessungen des Beckens

500 mm

Min. cabinet size
Minimalus spintelės plotis
Min. Schrankgröße

Supplied with
Komplekte
Enthalten

AQF-002V (AW) or / arba / oder
AQL-002V (AWP)

Recommended accessories
Rekomenduojami aksesuarai
Empfohlenes Zubehör

110 111 113 114 202 220 222 601 710

50

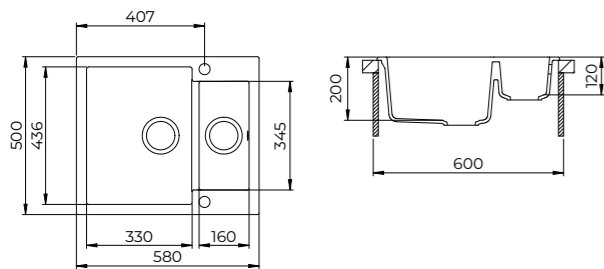

TESA SQT150

Topmounted
Iš viršaus
Einbau

Installation type
Montavimo būdas
Einbauart

580 x 500 mm

Sink dimensions
Plautuvės matmenys
Abmessungen der Spüle

330 x 436 x 200 mm
160 x 345 x 120 mm

Bowl dimensions
Dubens matmenys
Abmessungen des Beckens

600 mm

Min. cabinet size
Minimalus spintelės plotis
Min. Schrankgröße

AQF-003V (AW) or / arba / oder
AQL-003V (AWP)

Supplied with
Komplekte
Enthalten

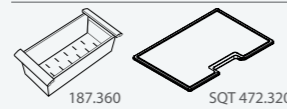

Recommended accessories
Rekomenduojami aksesuarai
Empfohlenes Zubehör

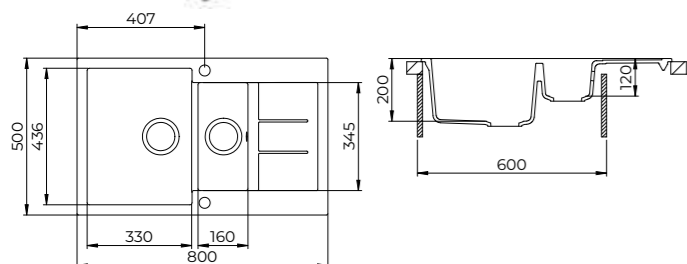
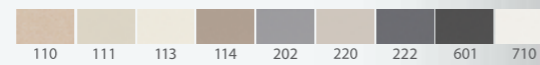

TESA SQT151

Topmounted
Iš viršaus
Einbau

Installation type
Montavimo būdas
Einbauart

800 x 500 mm

Sink dimensions
Plautuvės matmenys
Abmessungen der Spüle

330 x 436 x 200 mm
160 x 345 x 120 mm

Bowl dimensions
Dubens matmenys
Abmessungen des Beckens

600 mm

Min. cabinet size
Minimalus spintelės plotis
Min. Schrankgröße

AQF-003V (AW) or / arba / oder
AQL-003V (AWP)

Supplied with
Komplekte
Enthalten

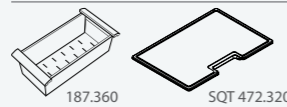

Recommended accessories
Rekomenduojami aksesuarai
Empfohlenes Zubehör

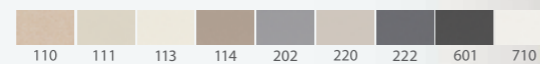



TESA PLUS SQT105

Topmounted
Iš viršaus
Einbau

Installation type
Montavimo būdas
Einbauart

780 x 500 mm

Sink dimensions
Plautuvės matmenys
Abmessungen der Spüle

480 x 436 x 200 mm

Bowl dimensions
Dubens matmenys
Abmessungen des Beckens

600 mm

Min. cabinet size
Minimalus spintelės plotis
Min. Schrankgröße

AQF-002V (AW) or / arba / oder
AQL-002V (AWP)

Supplied with
Komplekte
Enthalten

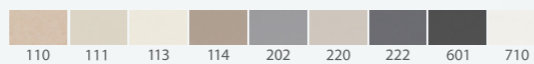
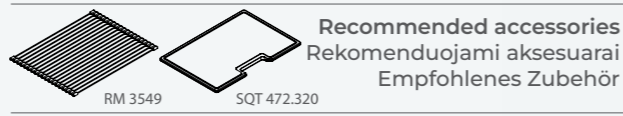

60

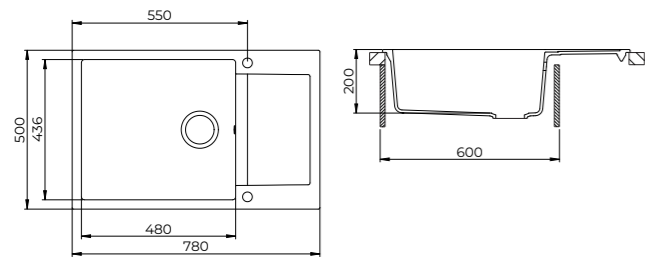

TESA PLUS SQT104

Topmounted
Iš viršaus
Einbau

Installation type
Montavimo būdas
Einbauart

860 x 500 mm

Sink dimensions
Plautuvės matmenys
Abmessungen der Spüle

480 x 436 x 200 mm

Bowl dimensions
Dubens matmenys
Abmessungen des Beckens

600 mm

Min. cabinet size
Minimalus spintelės plotis
Min. Schrankgröße

AQF-002V (AW) or / arba / oder
AQL-002V (AWP)

Supplied with
Komplekte
Enthalten

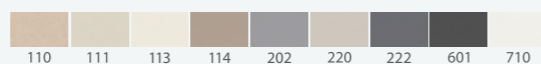
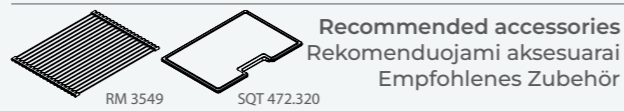

60

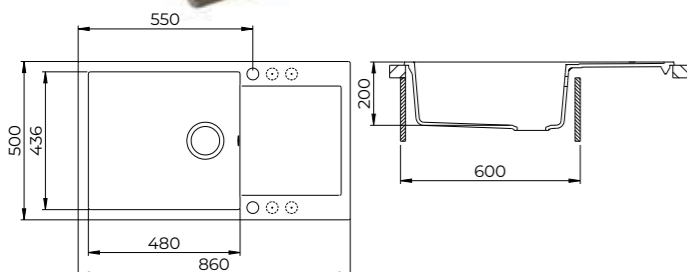

TESA PLUS SQT103

Topmounted
Iš viršaus
Einbau

Installation type
Montavimo būdas
Einbauart

1000 x 500 mm

Sink dimensions
Plautuvės matmenys
Abmessungen der Spüle

480 x 436 x 200 mm

Bowl dimensions
Dubens matmenys
Abmessungen des Beckens

600 mm

Min. cabinet size
Minimalus spintelės plotis
Min. Schrankgröße

AQF-002V (AW) or / arba / oder
AQL-002V (AWP)

Supplied with
Komplekte
Enthalten

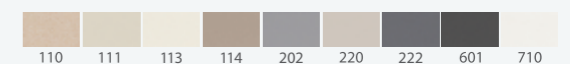
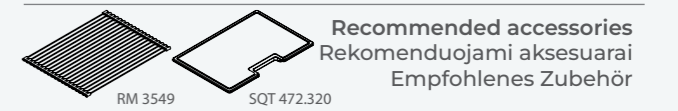

60

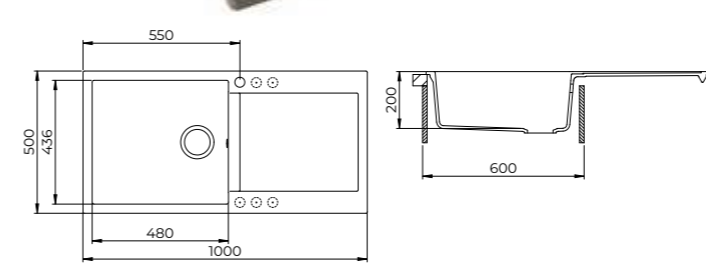

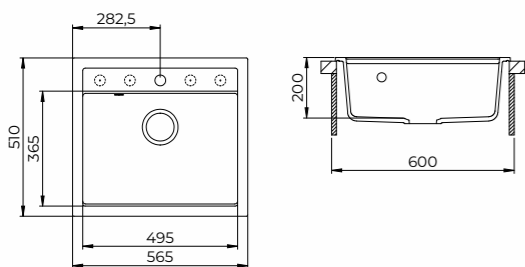

QUADRO SQQ100

Topmounted
Iš viršaus
Einbau

Installation type
Montavimo būdas
Einbautart

565 x 510 mm

Sink dimensions
Plautuvės matmenys
Abmessungen der Spüle

495 x 365 x 200 mm

Bowl dimensions
Dubens matmenys
Abmessungen des Beckens

600 mm

Min. cabinet size
Minimalus spintelės plotis
Min. Schrankgröße

AQF-001V (W) or / arba / oder
AQF-002V (AW) or / arba / oder
AQL-002V (AWP)

Supplied with
Komplekte
Enthalten

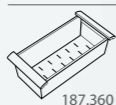

Recommended accessories
Rekomenduojami aksesuarai
Empfohlenes Zubehör

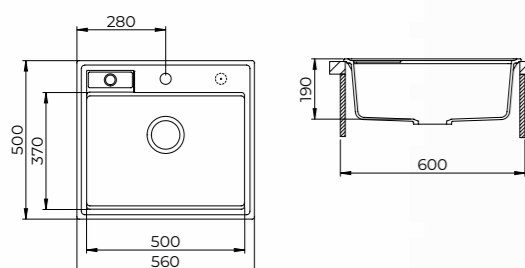
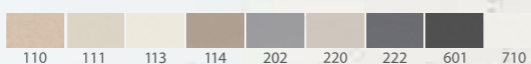
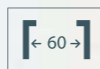

QUADRO SQU100

NEW

Topmounted
Iš viršaus
Einbau

Installation type
Montavimo būdas
Einbautart

560 x 500 mm

Sink dimensions
Plautuvės matmenys
Abmessungen der Spüle

500 x 370 x 190 mm

Bowl dimensions
Dubens matmenys
Abmessungen des Beckens

600 mm

Min. cabinet size
Minimalus spintelės plotis
Min. Schrankgröße

AQ-001H (W)

Supplied with
Komplekte
Enthalten

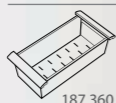

Recommended accessories
Rekomenduojami aksesuarai
Empfohlenes Zubehör

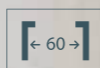

SQQ100W-601 / 5383-601 / AQF-001V



NEW

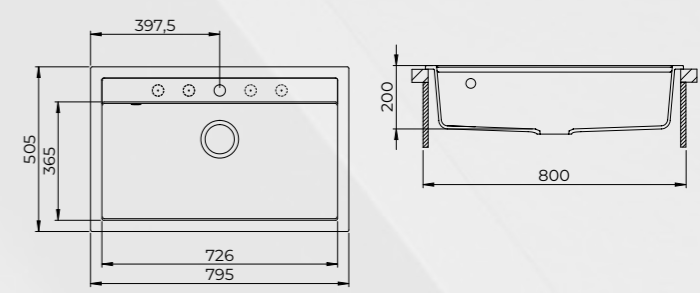

QUADRO SQQ103

Topmounted
Iš viršaus
Einbau

Installation type
Montavimo būdas
Einbauart

795 x 505 mm

Sink dimensions
Plautuvės matmenys
Abmessungen der Spüle

726 x 365 x 200 mm

Bowl dimensions
Dubens matmenys
Abmessungen des Beckens

800 mm

Min. cabinet size
Minimalus spintelės plotis
Min. Schrankgröße

AQF-001V (W) or / arba / oder
AQF-002V (AW) or / arba / oder
AQL-002V (AWP)

Supplied with
Komplekte
Enthalten

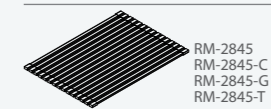

RM-2845
RM-2845-C
RM-2845-G
RM-2845-T

Recommended accessories
Rekomenduojami aksesuarai
Empfohlenes Zubehör

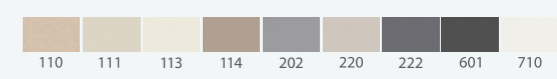

SQQ103W-601 / 2663L-MB / AQP-601



DELICIA SQD100

Undermounted
Iš apačios
Unterbau

Installation type
Montavimo būdas
Einbauart

555 x 455 mm

Sink dimensions
Plautuvės matmenys
Abmessungen der Spüle

505 x 405 x 200 mm

Bowl dimensions
Dubens matmenys
Abmessungen des Beckens

600 mm

Min. cabinet size
Minimalus spintelės plotis
Min. Schrankgröße

AQ-005H (W) or / arba / oder
AQ-006H (AW)

Supplied with
Komplekte
Enthalten

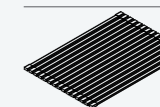

RM-2845
RM-2845-C
RM-2845-G
RM-2845-T

Recommended accessories
Rekomenduojami aksesuarai
Empfohlenes Zubehör

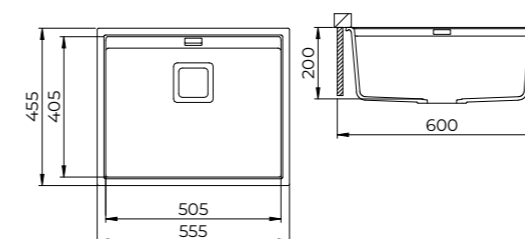
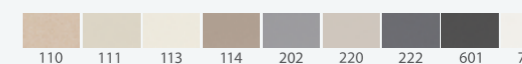
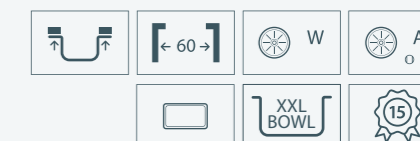

DELICIA SQD150

Undermounted
Iš apačios
Unterbau

Installation type
Montavimo būdas
Einbauart

650 x 455 mm

Sink dimensions
Plautuvės matmenys
Abmessungen der Spüle

375 x 405 x 200 mm
220 x 405 x 180 mm

Bowl dimensions
Dubens matmenys
Abmessungen des Beckens

800 mm

Min. cabinet size
Minimalus spintelės plotis
Min. Schrankgröße

AQ-008H (W) or / arba / oder
AQ-007H (AW)

Supplied with
Komplekte
Enthalten

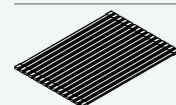

RM-2845
RM-2845-C
RM-2845-G
RM-2845-T

Recommended accessories
Rekomenduojami aksesuarai
Empfohlenes Zubehör

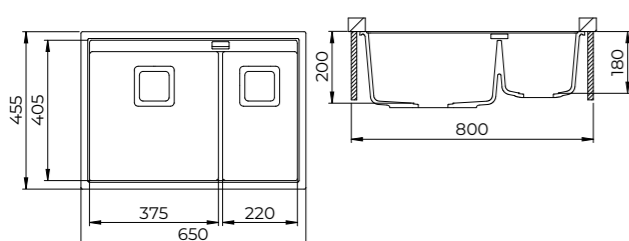
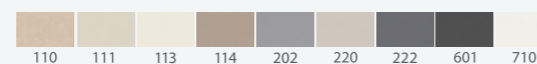
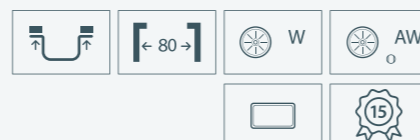

DELICIA SQD101

Undermounted
Iš apačios
Unterbau

Installation type
Montavimo būdas
Einbauart

740 x 455 mm

Sink dimensions
Plautuvės matmenys
Abmessungen der Spüle

690 x 405 x 200 mm

Bowl dimensions
Dubens matmenys
Abmessungen des Beckens

800 mm

Min. cabinet size
Minimalus spintelės plotis
Min. Schrankgröße

AQ-005H (W) or / arba / oder
AQ-006H (AW)

Supplied with
Komplekte
Enthalten

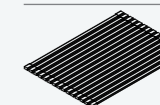

RM-2845
RM-2845-C
RM-2845-G
RM-2845-T

Recommended accessories
Rekomenduojami aksesuarai
Empfohlenes Zubehör

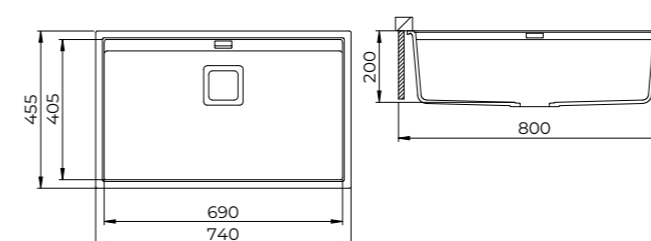
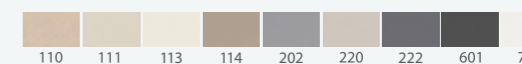
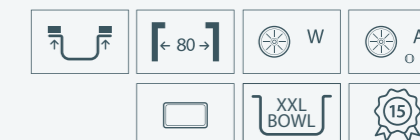

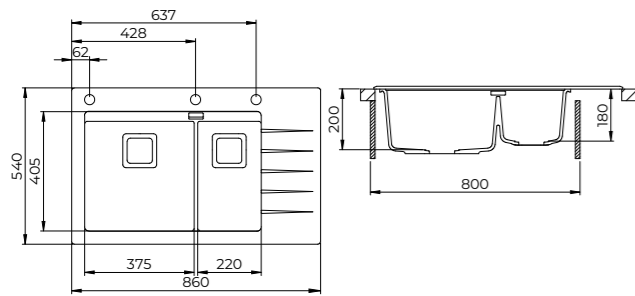

DELICIA PLUS GQD150B

Topmounted
Iš viršaus
Einbau

Installation type
Montavimo būdas
Einbauart

860 x 540 mm

Sink dimensions
Plautuvės matmenys
Abmessungen der Spüle

375 x 405 x 200 mm
220 x 405 x 180 mm

Bowl dimensions
Dubens matmenys
Abmessungen des Beckens

800 mm

Min. cabinet size
Minimalus spintelės plotis
Min. Schrankgröße

AQ-007H (AW)
DQ-001

Supplied with
Komplekte
Enthalten

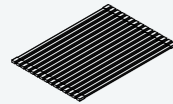

RM-2845
RM-2845-C
RM-2845-G
RM-2845-T

Recommended accessories
Rekomenduojami aksesuarai
Empfohlenes Zubehör

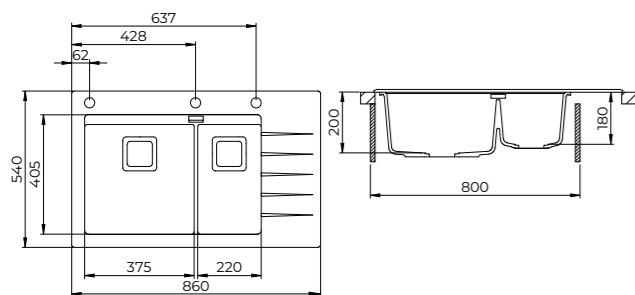
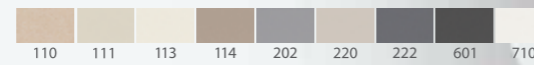
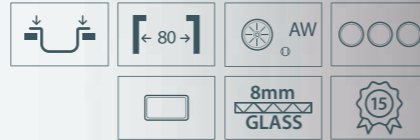

DELICIA PLUS GQD150W

Topmounted
Iš viršaus
Einbau

Installation type
Montavimo būdas
Einbauart

860 x 540 mm

Sink dimensions
Plautuvės matmenys
Abmessungen der Spüle

375 x 405 x 200 mm
220 x 405 x 180 mm

Bowl dimensions
Dubens matmenys
Abmessungen des Beckens

800 mm

Min. cabinet size
Minimalus spintelės plotis
Min. Schrankgröße

AQ-007H (AW)
DQ-001

Supplied with
Komplekte
Enthalten

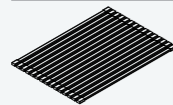

RM-2845
RM-2845-C
RM-2845-G
RM-2845-T

Recommended accessories
Rekomenduojami aksesuarai
Empfohlenes Zubehör

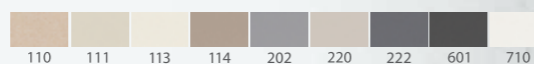
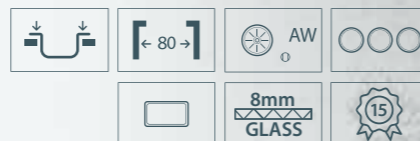

ECO1-601 / 2663L-601 / AQF-001V



ECO SERIES / SERIJA / SERIE

- ⦿ Saves space!
Economical packaging
Reduced transportation costs
- ⦿ Taupo vietą!
Ekonomiška pakuotė
Mažesnės transportavimo išlaidos
- ⦿ Spart Platz!
Wirtschaftliche Verpackung
Reduzierte Transportkosten

HELIKA[®]
Inspired by slow living



Where Ergonomics and Economy Meet

45



ECO 1

Topmounted
Iš viršaus
Einbau

Installation type
Montavimo būdas
Einbauart

Ø 450 mm

Sink dimensions
Plautuvės matmenys
Abmessungen der Spüle

390 x 325 x 170 mm

Bowl dimensions
Dubens matmenys
Abmessungen des Beckens

450 mm

Min. cabinet size
Minimalus spintelės plotis
Min. Schrankgröße

AQF-001V

Supplied with
Komplekte
Enthalten



Recommended accessories
Rekomenduojami aksesuarai
Empfohlenes Zubehör



45

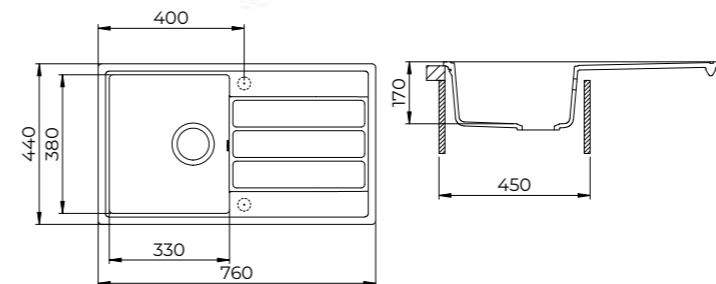

ECO 3

Topmounted
Iš viršaus
Einbau

Installation type
Montavimo būdas
Einbauart

760 x 440 mm

Sink dimensions
Plautuvės matmenys
Abmessungen der Spüle

330 x 380 x 170 mm

Bowl dimensions
Dubens matmenys
Abmessungen des Beckens

450 mm

Min. cabinet size
Minimalus spintelės plotis
Min. Schrankgröße

AQF-002V (AW) or / arba / oder
AQL-002V (AWP)

Supplied with
Komplekte
Enthalten



Recommended accessories
Rekomenduojami aksesuarai
Empfohlenes Zubehör



45



ECO 2

Topmounted
Iš viršaus
Einbau

Installation type
Montavimo būdas
Einbauart

620 x 440 mm

Sink dimensions
Plautuvės matmenys
Abmessungen der Spüle

330 x 380 x 170 mm

Bowl dimensions
Dubens matmenys
Abmessungen des Beckens

450 mm

Min. cabinet size
Minimalus spintelės plotis
Min. Schrankgröße

AQF-002V (AW) or / arba / oder
AQL-002V (AWP)

Supplied with
Komplekte
Enthalten



Recommended accessories
Rekomenduojami aksesuarai
Empfohlenes Zubehör



45

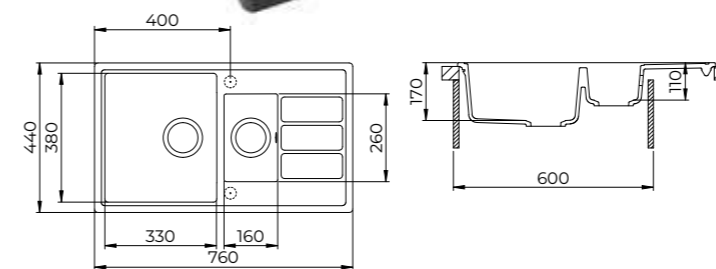

ECO 4

Topmounted
Iš viršaus
Einbau

Installation type
Montavimo būdas
Einbauart

760 x 440 mm

Sink dimensions
Plautuvės matmenys
Abmessungen der Spüle

330 x 380 x 170 mm
160 x 260 x 110 mm

Bowl dimensions
Dubens matmenys
Abmessungen des Beckens

600 mm

Min. cabinet size
Minimalus spintelės plotis
Min. Schrankgröße

AQF-003V (AW) or / arba / oder
AQL-003V (AWP)

Supplied with
Komplekte
Enthalten



Recommended accessories
Rekomenduojami aksesuarai
Empfohlenes Zubehör

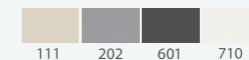

60



SIMPLEX SQS100

Topmounted
Iš viršaus
Einbau

Installation type
Montavimo būdas
Einbauart

425 x 500 mm

Sink dimensions
Plautuvės matmenys
Abmessungen der Spüle

350 x 390 x 195 mm

Bowl dimensions
Dubens matmenys
Abmessungen des Beckens

450 mm

Min. cabinet size
Minimalus spintelės plotis
Min. Schrankgröße

AQF-001V (W) or / arba / oder
AQF-002V (AW) or / arba / oder
AQL-002V (AWP)

Supplied with
Komplekte
Enthalten

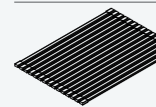

RM-2845
RM-2845-C
RM-2845-G
RM-2845-T

Recommended accessories
Rekomenduojami aksesuarai
Empfohlenes Zubehör

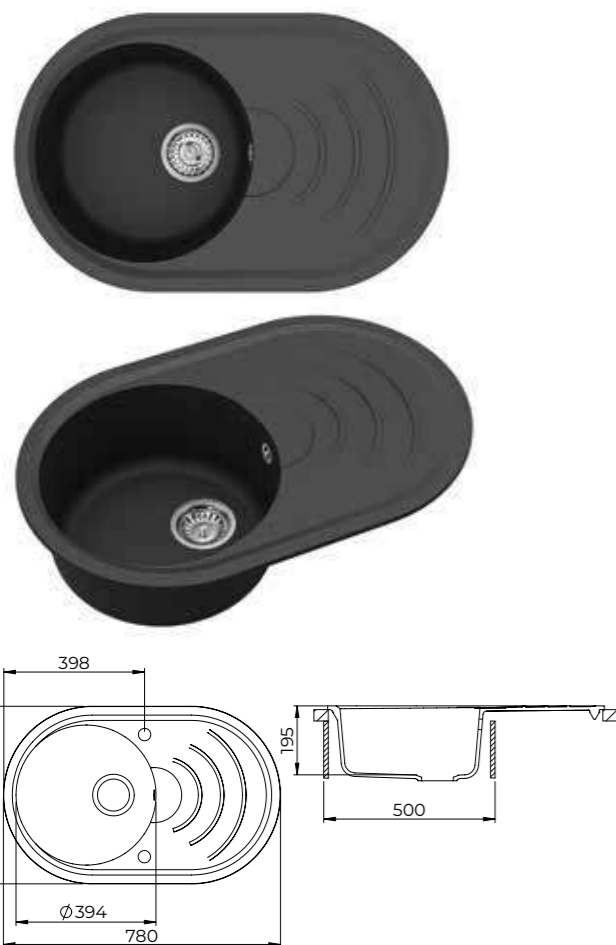
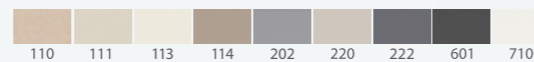

ONDO MP100

Topmounted
Iš viršaus
Einbau

Installation type
Montavimo būdas
Einbauart

780 x 500 mm

Sink dimensions
Plautuvės matmenys
Abmessungen der Spüle

Ø 394 x 195 mm

Bowl dimensions
Dubens matmenys
Abmessungen des Beckens

500 mm

Min. cabinet size
Minimalus spintelės plotis
Min. Schrankgröße

AQF-002V (AW) or / arba / oder
AQL-002V (AWP)

Supplied with
Komplekte
Enthalten



ST-601
ST-710

Recommended accessories
Rekomenduojami aksesuarai
Empfohlenes Zubehör

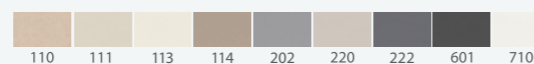
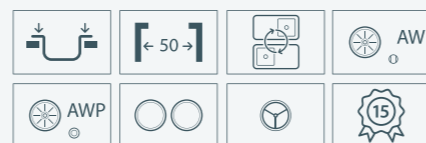

NOVA SQN100

Topmounted
Iš viršaus
Einbau

Installation type
Montavimo būdas
Einbauart

460 x 515 mm

Sink dimensions
Plautuvės matmenys
Abmessungen der Spüle

390 x 375 x 200 mm

Bowl dimensions
Dubens matmenys
Abmessungen des Beckens

450 mm

Min. cabinet size
Minimalus spintelės plotis
Min. Schrankgröße

AQF-001V (W) or / arba / oder
AQF-002V (AW) or / arba / oder
AQL-002V (AWP)

Supplied with
Komplekte
Enthalten

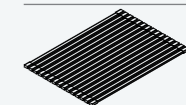

RM-2845
RM-2845-C
RM-2845-G
RM-2845-T

Recommended accessories
Rekomenduojami aksesuarai
Empfohlenes Zubehör

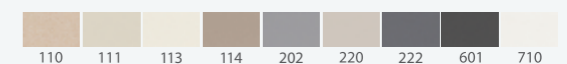

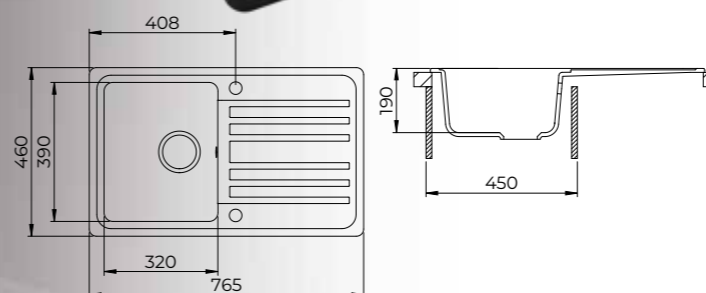

NOTUS SQ101

Topmounted
Iš viršaus
Einbau

Installation type
Montavimo būdas
Einbauart

765 x 460 mm

Sink dimensions
Plautuvės matmenys
Abmessungen der Spüle

320 x 390 x 190 mm

Bowl dimensions
Dubens matmenys
Abmessungen des Beckens

450 mm

Min. cabinet size
Minimalus spintelės plotis
Min. Schrankgröße

AQF-002V (AW) or / arba / oder
AQL-002V (AWP)

Supplied with
Komplekte
Enthalten

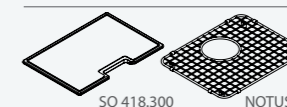

Recommended accessories
Rekomenduojami aksesuarai
Empfohlenes Zubehör

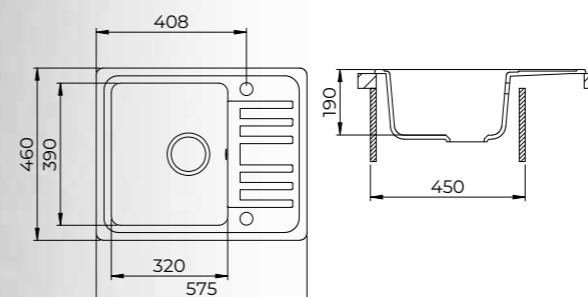
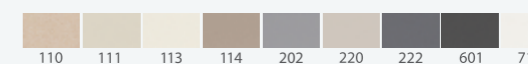
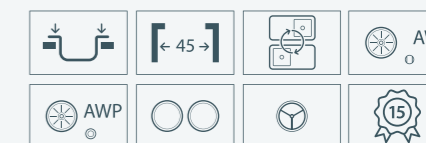

NOTUS SQ102

Topmounted
Iš viršaus
Einbau

Installation type
Montavimo būdas
Einbauart

575 x 460 mm

Sink dimensions
Plautuvės matmenys
Abmessungen der Spüle

320 x 390 x 190 mm

Bowl dimensions
Dubens matmenys
Abmessungen des Beckens

450 mm

Min. cabinet size
Minimalus spintelės plotis
Min. Schrankgröße

AQF-002V (AW) or / arba / oder
AQL-002V (AWP)

Supplied with
Komplekte
Enthalten



Recommended accessories
Rekomenduojami aksesuarai
Empfohlenes Zubehör

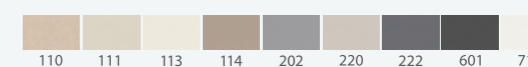
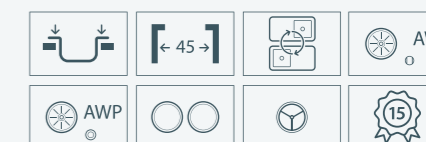

45



CLARUS SR100

Topmounted
Iš viršaus
Einbau

Installation type
Montavimo būdas
Einbautart

Ø 505 mm

Sink dimensions
Plautuvės matmenys
Abmessungen der Spüle

Ø 395 x 190 mm

Bowl dimensions
Dubens matmenys
Abmessungen des Beckens

450 mm

Min. cabinet size
Minimalus spintelės plotis
Min. Schrankgröße

AQF-001V (W) or / arba / oder
AQF-002V (AW) or / arba / oder
AQL-002V (AWP)

Supplied with
Komplekte
Enthalten



Recommended accessories
Rekomenduojami aksesuarai
Empfohlenes Zubehör

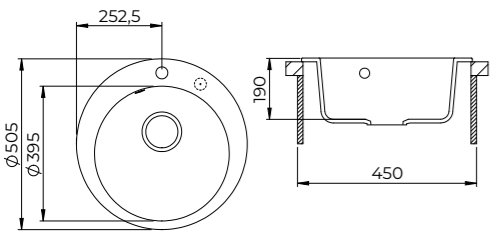

SR100W-220 / 5523JG-601 / AQP-601

50



CLARUS SR102

Topmounted
Iš viršaus
Einbau

Installation type
Montavimo būdas
Einbautart

580 x 470 mm

Sink dimensions
Plautuvės matmenys
Abmessungen der Spüle

Ø 395 x 190 mm

Bowl dimensions
Dubens matmenys
Abmessungen des Beckens

500 mm

Min. cabinet size
Minimalus spintelės plotis
Min. Schrankgröße

AQ-002H (AW)

Supplied with
Komplekte
Enthalten



Recommended accessories
Rekomenduojami aksesuarai
Empfohlenes Zubehör

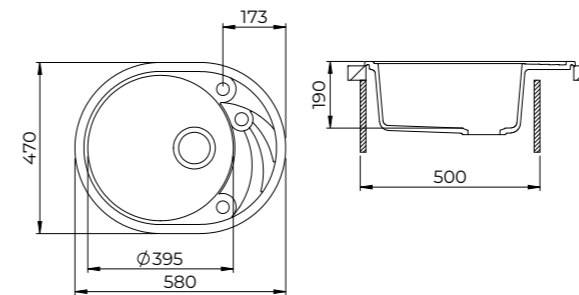
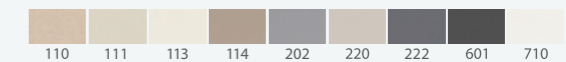

50

CLARUS SR101

Topmounted
Iš viršaus
Einbau

Installation type
Montavimo būdas
Einbautart

780 x 500 mm

Sink dimensions
Plautuvės matmenys
Abmessungen der Spüle

Ø 420 x 195 mm

Bowl dimensions
Dubens matmenys
Abmessungen des Beckens

500 mm

Min. cabinet size
Minimalus spintelės plotis
Min. Schrankgröße

AQF-002V (AW) or / arba / oder
AQL-002V (AWP)

Supplied with
Komplekte
Enthalten

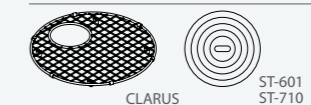

Recommended accessories
Rekomenduojami aksesuarai
Empfohlenes Zubehör

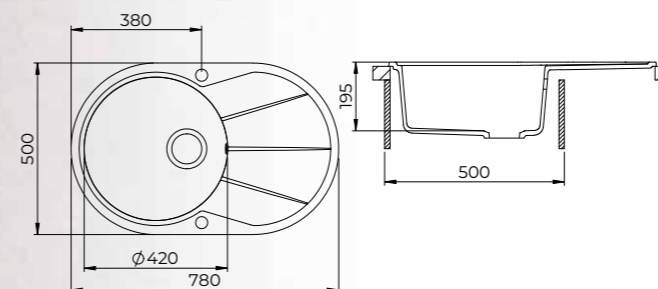
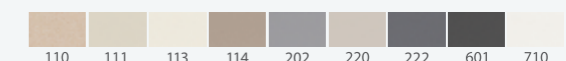
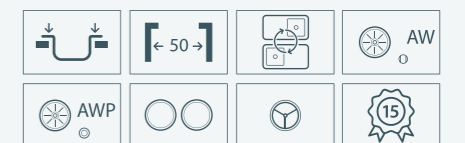

HELIKA[®]
Inspired by slow living

KOPA
SERIJA / SERIE

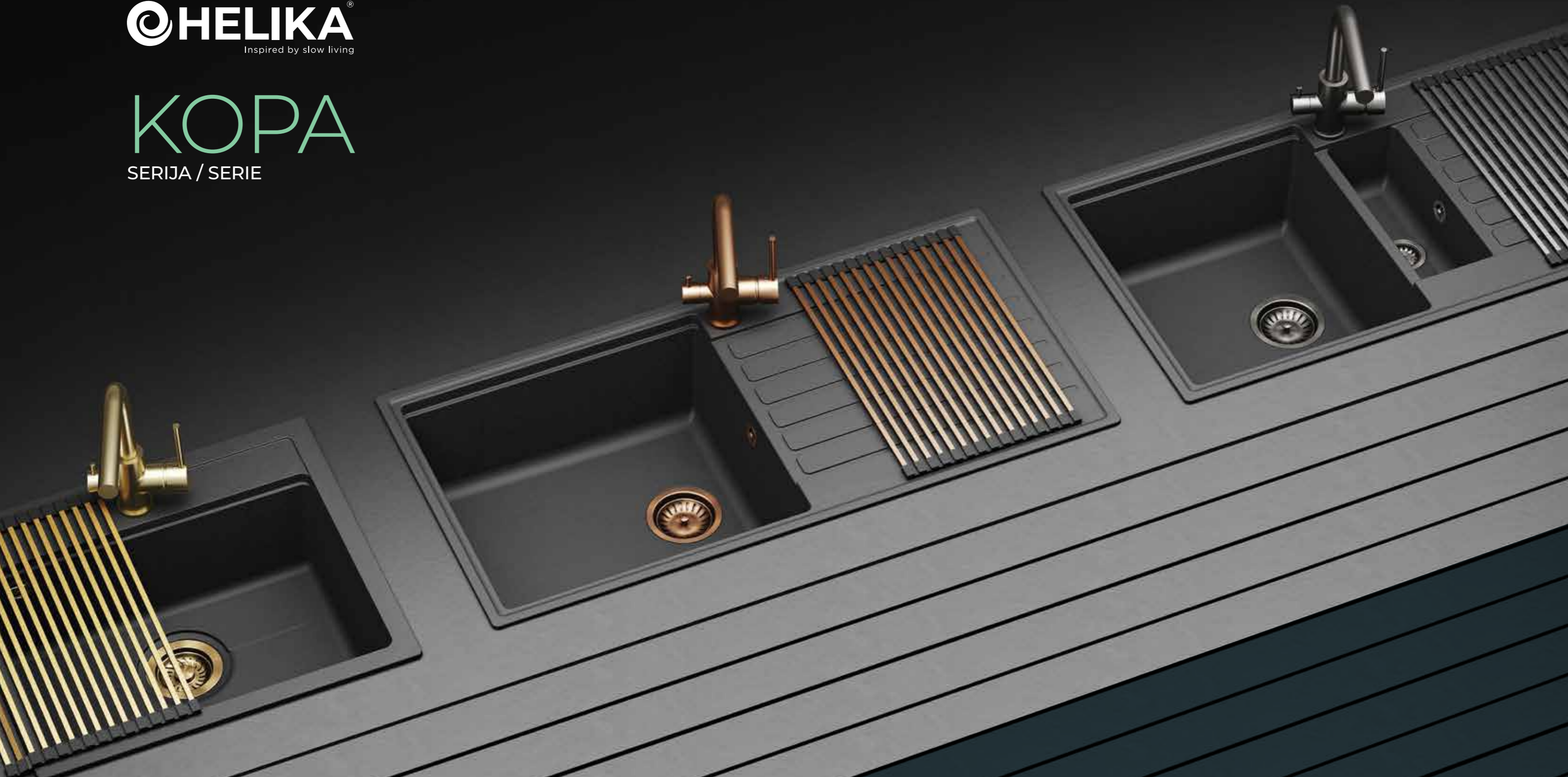

SQK100W-601 / 2663L-G / AQF-001V-G / RM-2845-G
SQK103W-601 / 2663L-C / AQF-001V-C / RM-2845-C
SQK151W-601 / 2663L-T / AQF-001V-T / RM-2845-T

NEW

Convenience in your kitchen

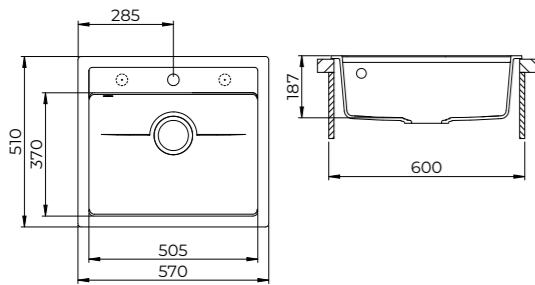

KOPA SQK100

NEW

Topmounted
Iš viršaus
Einbau

Installation type
Montavimo būdas
Einbauart

570 x 510 mm

Sink dimensions
Plautuvės matmenys
Abmessungen der Spüle

505 x 370 x 187 mm

Bowl dimensions
Dubens matmenys
Abmessungen des Beckens

600 mm

Min. cabinet size
Minimalus spintelės plotis
Min. Schrankgröße

AQF-001V (W) or / arba / oder
AQF-002V (AW) or / arba / oder
AQL-002V (AWP)

Supplied with
Komplekte
Enthalten

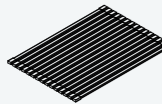

RM-2845
RM-2845-C
RM-2845-G
RM-2845-T

Recommended accessories
Rekomenduojami aksesuarai
Empfohlenes Zubehör

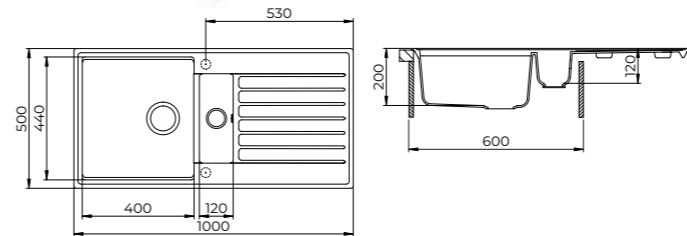

KOPA SQK151

NEW

Topmounted
Iš viršaus
Einbau

Installation type
Montavimo būdas
Einbauart

1000 x 500 mm

Sink dimensions
Plautuvės matmenys
Abmessungen der Spüle

400 x 440 x 200 mm
120 x 320 x 120 mm

Bowl dimensions
Dubens matmenys
Abmessungen des Beckens

600 mm

Min. cabinet size
Minimalus spintelės plotis
Min. Schrankgröße

AQF-009V (W)

Supplied with
Komplekte
Enthalten

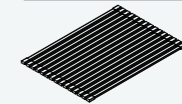

RM-2845
RM-2845-C
RM-2845-G
RM-2845-T

Recommended accessories
Rekomenduojami aksesuarai
Empfohlenes Zubehör

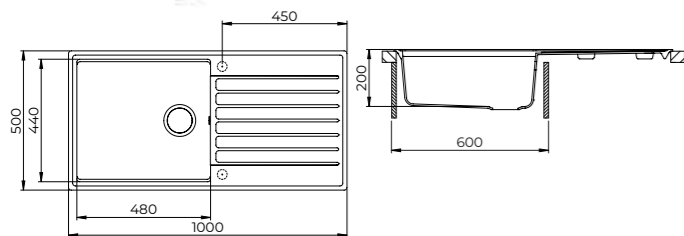

KOPA SQK103

NEW

Topmounted
Iš viršaus
Einbau

Installation type
Montavimo būdas
Einbauart

1000 x 500 mm

Sink dimensions
Plautuvės matmenys
Abmessungen der Spüle

480 x 440 x 200 mm

Bowl dimensions
Dubens matmenys
Abmessungen des Beckens

600 mm

Min. cabinet size
Minimalus spintelės plotis
Min. Schrankgröße

AQF-001V (W) or / arba / oder
AQF-002V (AW) or / arba / oder
AQL-002V (AWP)

Supplied with
Komplekte
Enthalten

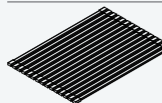

RM-2845
RM-2845-C
RM-2845-G
RM-2845-T

Recommended accessories
Rekomenduojami aksesuarai
Empfohlenes Zubehör

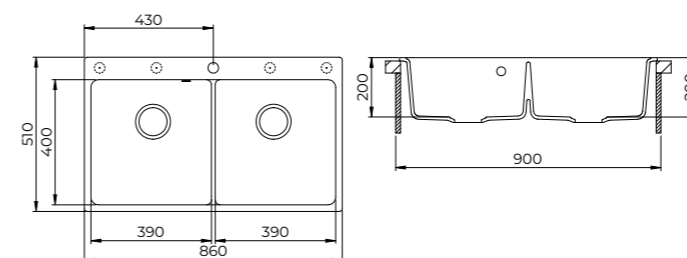
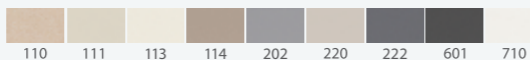

MAGNA SQM200

Topmounted
Iš viršaus
Einbau

Installation type
Montavimo būdas
Einbauart

860 x 510 mm

Sink dimensions
Plautuvės matmenys
Abmessungen der Spüle

390 x 400 x 200 mm
390 x 400 x 200 mm

Bowl dimensions
Dubens matmenys
Abmessungen des Beckens

900 mm

Min. cabinet size
Minimalus spintelės plotis
Min. Schrankgröße

AQF-005V (W) or / arba / oder
AQF-003V (AW) or / arba / oder
AQL-003V (AWP)

Supplied with
Komplekte
Enthalten

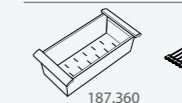

RM 3549

Recommended accessories
Rekomenduojami aksesuarai
Empfohlenes Zubehör

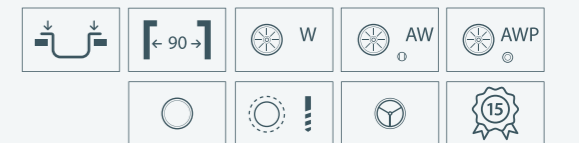

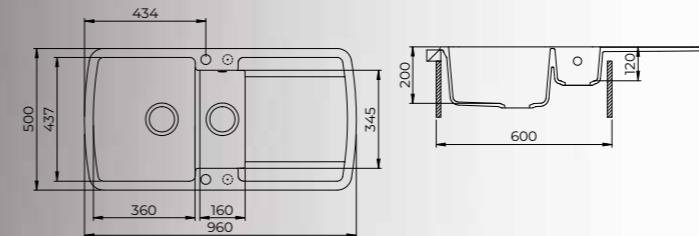

LIRA SQL151

Topmounted
Iš viršaus
Einbau

Installation type
Montavimo būdas
Einbauart

960 x 500 mm

Sink dimensions
Plautuvės matmenys
Abmessungen der Spüle

360 x 437 x 200 mm
160 x 345 x 120 mm

Bowl dimensions
Dubens matmenys
Abmessungen des Beckens

600 mm

Min. cabinet size
Minimalus spintelės plotis
Min. Schrankgröße

AQF-003V (AW) or / arba / oder
AQL-003V (AWP)

Supplied with
Komplekte
Enthalten

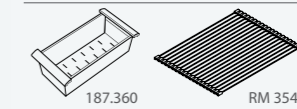

Recommended accessories
Rekomenduojami aksesuarai
Empfohlenes Zubehör

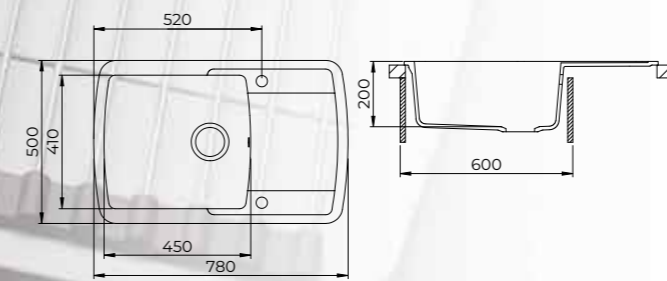
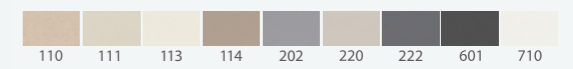

LIRA SQL101

Topmounted
Iš viršaus
Einbau

Installation type
Montavimo būdas
Einbauart

780 x 500 mm

Sink dimensions
Plautuvės matmenys
Abmessungen der Spüle

450 x 410 x 200 mm

Bowl dimensions
Dubens matmenys
Abmessungen des Beckens

600 mm

Min. cabinet size
Minimalus spintelės plotis
Min. Schrankgröße

AQF-002V (AW) or / arba / oder
AQL-002V (AWP)

Supplied with
Komplekte
Enthalten

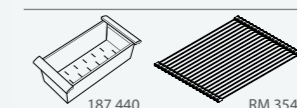

Recommended accessories
Rekomenduojami aksesuarai
Empfohlenes Zubehör

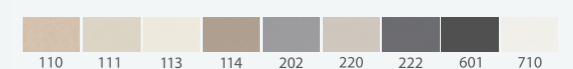
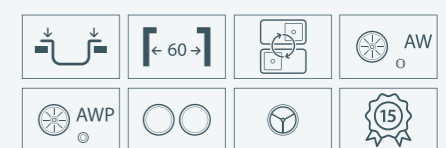



SQB101AW-601 / 7083-601 / AQF-002V

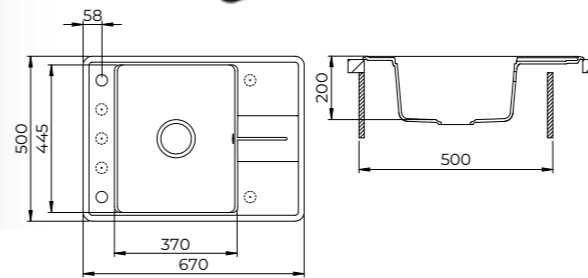

BELLA SQB102

Topmounted
Iš viršaus
Einbau

Installation type
Montavimo būdas
Einbauart

670 x 500 mm

Sink dimensions
Plautuvės matmenys
Abmessungen der Spüle

370 x 445 x 200 mm

Bowl dimensions
Dubens matmenys
Abmessungen des Beckens

500 mm

Min. cabinet size
Minimalus spintelės plotis
Min. Schrankgröße

AQF-002V (AW) or / arba / oder
AQL-002V (AWP)

Supplied with
Komplekte
Enthalten

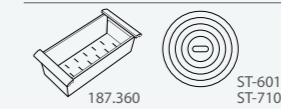

Recommended accessories
Rekomenduojami aksesuarai
Empfohlenes Zubehör

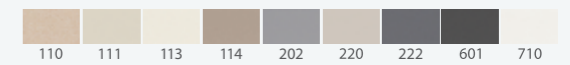

BELLA SQB101

Topmounted
Iš viršaus
Einbau

Installation type
Montavimo būdas
Einbauart

780 x 500 mm

Sink dimensions
Plautuvės matmenys
Abmessungen der Spüle

370 x 445 x 200 mm

Bowl dimensions
Dubens matmenys
Abmessungen des Beckens

500 mm

Min. cabinet size
Minimalus spintelės plotis
Min. Schrankgröße

AQF-002V (AW) or / arba / oder
AQL-002V (AWP)

Supplied with
Komplekte
Enthalten



Recommended accessories
Rekomenduojami aksesuarai
Empfohlenes Zubehör

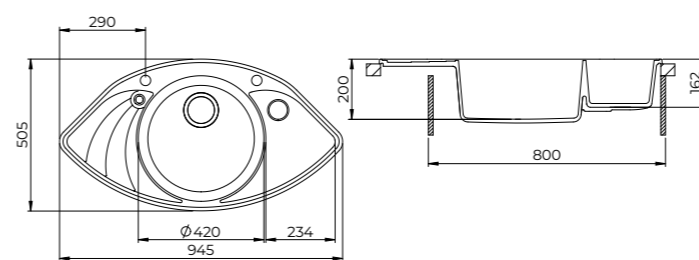

PAPPILON SCP151

Topmounted
Iš viršaus
Einbau

Installation type
Montavimo būdas
Einbauart

945 x 505 mm

Sink dimensions
Plautuvės matmenys
Abmessungen der Spüle

Ø 420 x 200 mm
234 x 320 x 162 mm

Bowl dimensions
Dubens matmenys
Abmessungen des Beckens

800 mm

Min. cabinet size
Minimalus spintelės plotis
Min. Schrankgröße

AQ-004H (AW)

Supplied with
Komplekte
Enthalten



Recommended accessories
Rekomenduojami aksesuarai
Empfohlenes Zubehör

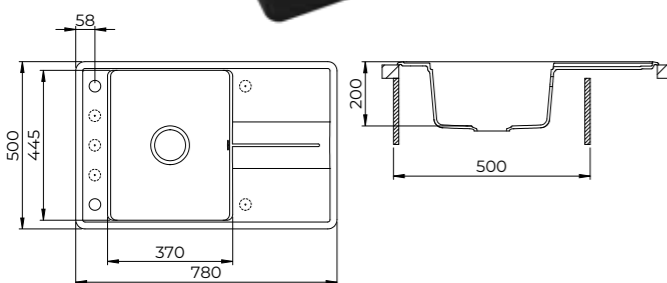
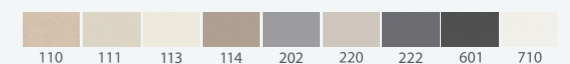

45

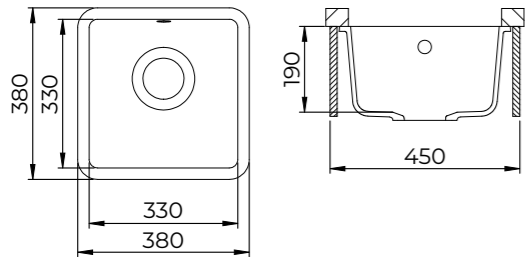

ARCA SQA100

Undermounted
Iš apačios
Unterbau

Installation type
Montavimo būdas
Einbauart

380 x 380 mm

Sink dimensions
Plautuvės matmenys
Abmessungen der Spüle

330 x 330 x 190 mm

Bowl dimensions
Dubens matmenys
Abmessungen des Beckens

450 mm

Min. cabinet size
Minimalus spintelės plotis
Min. Schrankgröße

AQF-001V (W) or / arba / oder
AQF-002V (AW) or / arba / oder
AQL-002V (AWP)

Supplied with
Komplekte
Enthalten

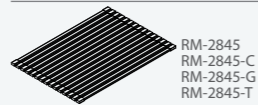

Recommended accessories
Rekomenduojami aksesuarai
Empfohlenes Zubehör

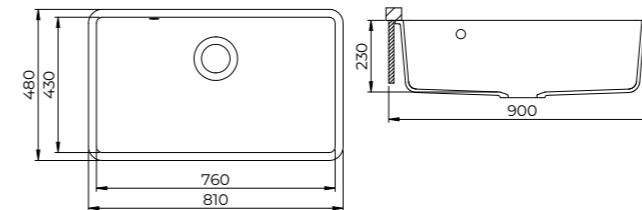
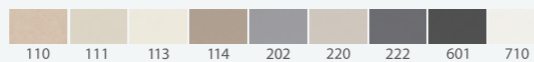
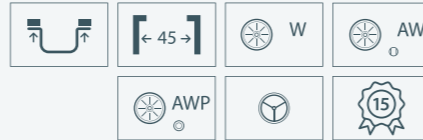

ARCA SQA104

Undermounted
Iš apačios
Unterbau

Installation type
Montavimo būdas
Einbauart

810 x 480 mm

Sink dimensions
Plautuvės matmenys
Abmessungen der Spüle

760 x 430 x 230 mm

Bowl dimensions
Dubens matmenys
Abmessungen des Beckens

900 mm

Min. cabinet size
Minimalus spintelės plotis
Min. Schrankgröße

AQF-001V (W) or / arba / oder
AQF-002V (AW) or / arba / oder
AQL-002V (AWP)

Supplied with
Komplekte
Enthalten

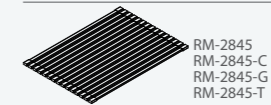

Recommended accessories
Rekomenduojami aksesuarai
Empfohlenes Zubehör

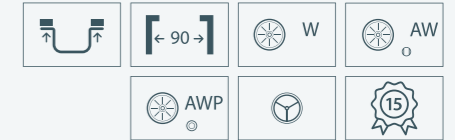

90

50

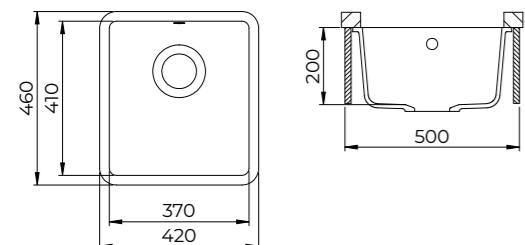

ARCA SQA101

Undermounted
Iš apačios
Unterbau

Installation type
Montavimo būdas
Einbauart

420 x 460 mm

Sink dimensions
Plautuvės matmenys
Abmessungen der Spüle

370 x 410 x 200 mm

Bowl dimensions
Dubens matmenys
Abmessungen des Beckens

500 mm

Min. cabinet size
Minimalus spintelės plotis
Min. Schrankgröße

AQF-001V (W) or / arba / oder
AQF-002V (AW) or / arba / oder
AQL-002V (AWP)

Supplied with
Komplekte
Enthalten

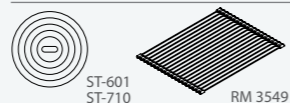

Recommended accessories
Rekomenduojami aksesuarai
Empfohlenes Zubehör

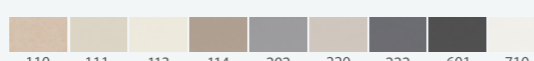
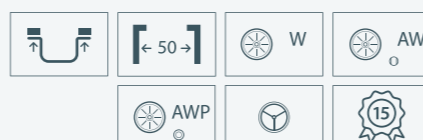

SQA104W-601 / 7023-601 / AQP-601

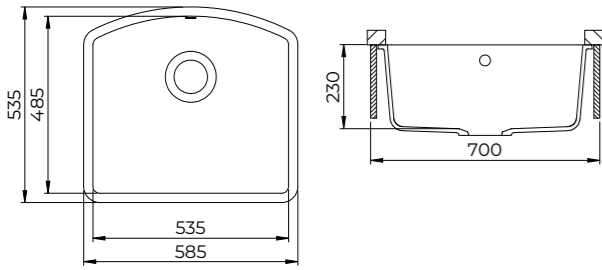

ARCA SQA103

Undermounted
Iš apačios
Unterbau

Installation type
Montavimo būdas
Einbauart

585 x 535 mm

Sink dimensions
Plautuvės matmenys
Abmessungen der Spüle

535 x 485 x 230 mm

Bowl dimensions
Dubens matmenys
Abmessungen des Beckens

700 mm

Min. cabinet size
Minimalus spintelės plotis
Min. Schrankgröße

AQF-001V (W) or / arba / oder
AQF-002V (AW) or / arba / oder
AQL-002V (AWP)

Supplied with
Komplekte
Enthalten



Recommended accessories
Rekomenduojami aksesuarai
Empfohlenes Zubehör

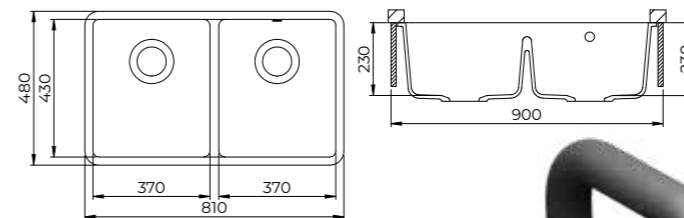
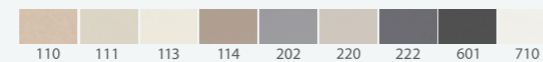

ARCA SQA200

Undermounted
Iš apačios
Unterbau

Installation type
Montavimo būdas
Einbauart

810 x 480 mm

Sink dimensions
Plautuvės matmenys
Abmessungen der Spüle

370 x 430 x 230 mm
370 x 430 x 230 mm

Bowl dimensions
Dubens matmenys
Abmessungen des Beckens

900 mm

Min. cabinet size
Minimalus spintelės plotis
Min. Schrankgröße

AQF-005V (W) or / arba / oder
AQF-003V (AW) or / arba / oder
AQL-003V (AWP)

Supplied with
Komplekte
Enthalten

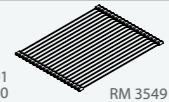

Recommended accessories
Rekomenduojami aksesuarai
Empfohlenes Zubehör

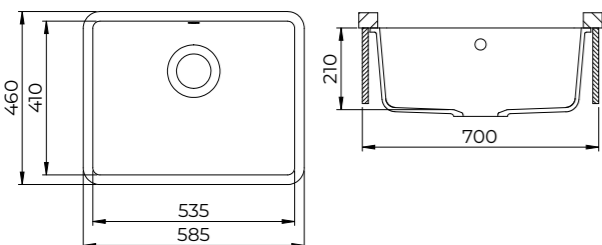

ARCA SQA102

Undermounted
Iš apačios
Unterbau

Installation type
Montavimo būdas
Einbauart

585 x 460 mm

Sink dimensions
Plautuvės matmenys
Abmessungen der Spüle

535 x 410 x 210 mm

Bowl dimensions
Dubens matmenys
Abmessungen des Beckens

700 mm

Min. cabinet size
Minimalus spintelės plotis
Min. Schrankgröße

AQF-001V (W) or / arba / oder
AQF-002V (AW) or / arba / oder
AQL-002V (AWP)

Supplied with
Komplekte
Enthalten

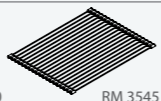

Recommended accessories
Rekomenduojami aksesuarai
Empfohlenes Zubehör

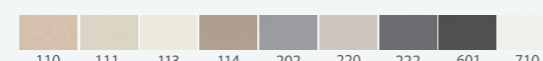
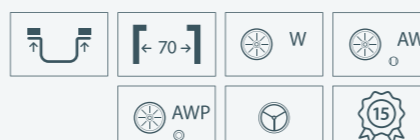

SQA200W-601 / 7023-601 /
AQF-005V / DTQ-601CR





ARCA SQA210

Topmounted
Iš viršaus
Einbau

Installation type
Montavimo būdas
Einbauart

840 x 560 mm

Sink dimensions
Plautuvės matmenys
Abmessungen der Spüle

380 x 460 x 230 mm
380 x 460 x 230 mm

Bowl dimensions
Dubens matmenys
Abmessungen des Beckens

900 mm

Min. cabinet size
Minimalus spintelės plotis
Min. Schrankgröße

AQF-005V (W) or / arba / oder
AQF-003V (AW) or / arba / oder
AQL-003V (AWP)

Supplied with
Komplekte
Enthalten



Recommended accessories
Rekomenduojami aksesuarai
Empfohlenes Zubehör

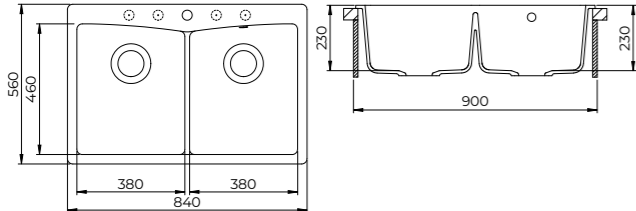
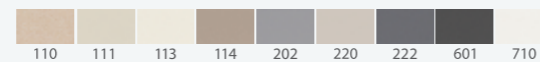

ARCA SQA230L/R

Undermounted
Iš apačios
Unterbau

Installation type
Montavimo būdas
Einbauart

810 x 480 mm

Sink dimensions
Plautuvės matmenys
Abmessungen der Spüle

310 x 380 x 190 mm
430 x 430 x 230 mm

Bowl dimensions
Dubens matmenys
Abmessungen des Beckens

900 mm

Min. cabinet size
Minimalus spintelės plotis
Min. Schrankgröße

AQF-005V (W) or / arba / oder
AQF-003V (AW) or / arba / oder
AQL-003V (AWP)

Supplied with
Komplekte
Enthalten

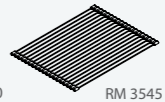

Recommended accessories
Rekomenduojami aksesuarai
Empfohlenes Zubehör

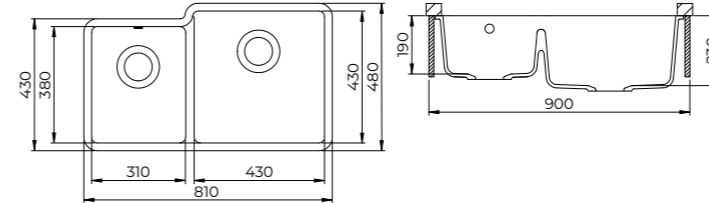

ARCA SQA220

Undermounted
Iš apačios
Unterbau

Installation type
Montavimo būdas
Einbauart

810 x 520 mm

Sink dimensions
Plautuvės matmenys
Abmessungen der Spüle

430 x 470 x 240 mm
300 x 390 x 200 mm

Bowl dimensions
Dubens matmenys
Abmessungen des Beckens

900 mm

Min. cabinet size
Minimalus spintelės plotis
Min. Schrankgröße

AQF-005V (W) or / arba / oder
AQF-003V (AW) or / arba / oder
AQL-003V (AWP)

Supplied with
Komplekte
Enthalten

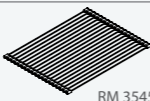

Recommended accessories
Rekomenduojami aksesuarai
Empfohlenes Zubehör

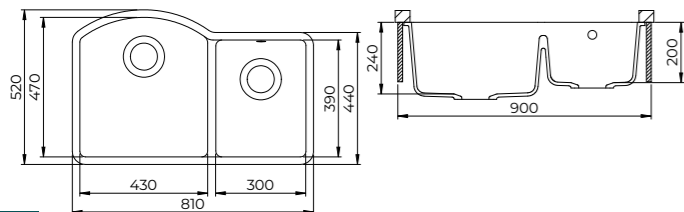
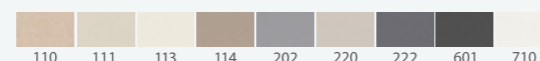
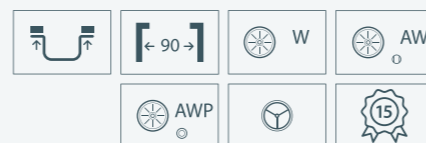

LARGUS TQL100

Topmounted
Iš viršaus
Einbau

Installation type
Montavimo būdas
Einbauart

840 x 560 mm

Sink dimensions
Plautuvės matmenys
Abmessungen der Spüle

770 x 430 x 240 mm

Bowl dimensions
Dubens matmenys
Abmessungen des Beckens

900 mm

Min. cabinet size
Minimalus spintelės plotis
Min. Schrankgröße

AQF-001V (W) or / arba / oder
AQF-002V (AW) or / arba / oder
AQL-002V (AWP)

Supplied with
Komplekte
Enthalten

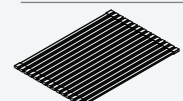

Recommended accessories
Rekomenduojami aksesuarai
Empfohlenes Zubehör

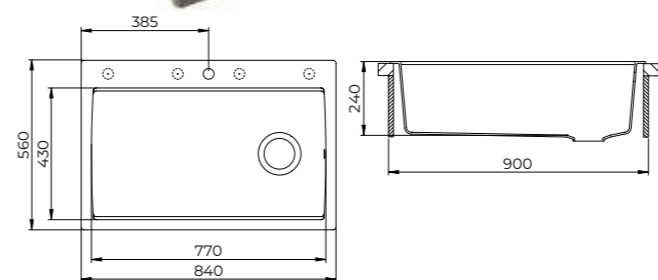

NEW

DIAMANTO TPD101

Topmounted
Iš viršaus
Einbau

Installation type
Montavimo būdas
Einbauart

780 x 500 mm

Sink dimensions
Plautuvės matmenys
Abmessungen der Spüle

430 x 430 x 200 mm

Bowl dimensions
Dubens matmenys
Abmessungen des Beckens

600 mm

Min. cabinet size
Minimalus spintelės plotis
Min. Schrankgröße

AQF-002V (AW) or / arba / oder
AQL-002V (AWP)

Supplied with
Komplekte
Enthalten

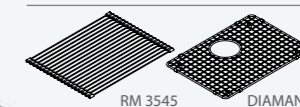

Recommended accessories
Rekomenduojami aksesuarai
Empfohlenes Zubehör

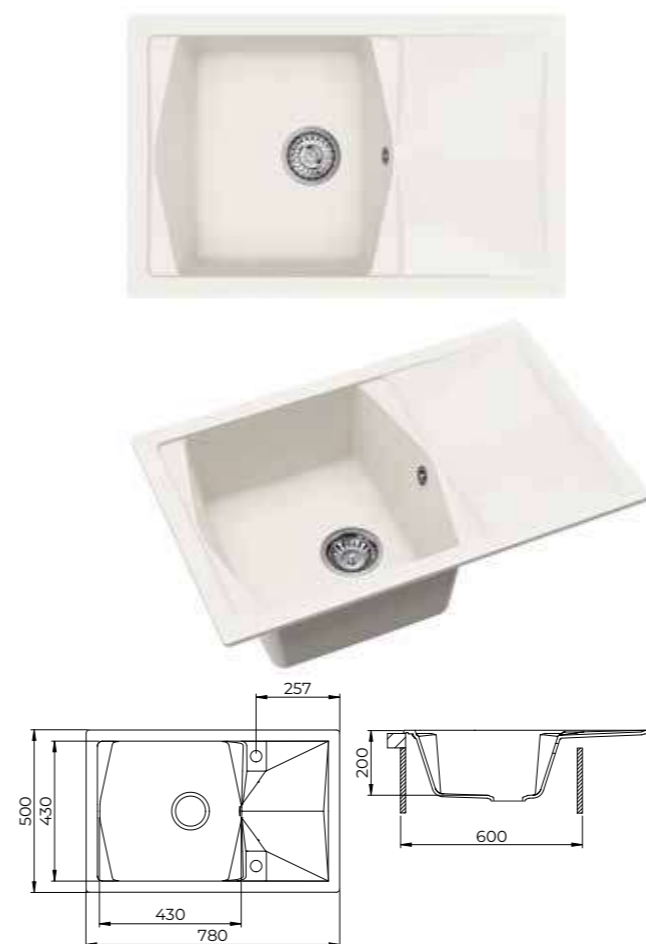
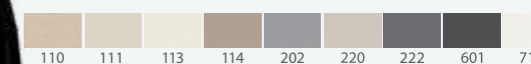
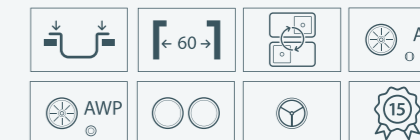

GQV100W-710 / 2473-610 /
AQP-610 / D-601

VILLA PREMIUM GQV100

Undermounted
Iš apačios
Unterbau

Installation type
Montavimo būdas
Einbauart

838 x 508 mm

Sink dimensions
Plautuvės matmenys
Abmessungen der Spüle

778 x 448 x 238 mm

Bowl dimensions
Dubens matmenys
Abmessungen des Beckens

900 mm

Min. cabinet size
Minimalus spintelės plotis
Min. Schrankgröße

AQF-001V (W) or / arba / oder
AQF-002V (AW) or / arba / oder
AQL-002V (AWP)

Supplied with
Komplekte
Enthalten



Recommended accessories
Rekomenduojami aksesuarai
Empfohlenes Zubehör

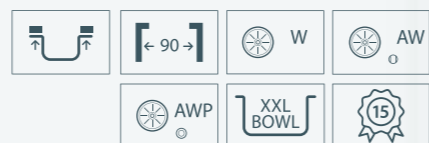

TPD101-710 / 5523JG-700 /
AQL-002V / DTQ-601CR

STAINLESS STEEL SINKS

NERŪDIJANČIO PLIENO PLAUTUVĖS / EDELSTAHLSPÜLEN

The stainless steel sinks are manufactured from AISI 304 steel. **HELIKA**® stainless steel sinks are made of 1-2 mm thick steel, which ensures stability and resistance to denting. A satin brushed surface facilitates effortless cleaning.

HELIKA® nerūdijančio plieno plautuvės pagamintos iš AISI 304, 1-2 mm storio nerūdijančio plieno, kuris užtikrina stabilumą ir atsparumą įlenkimams. Satino šlifluotas paviršius palengvina plautuvės priežiūrą.

Die Edelstahlspülen werden aus AISI 304 Stahl hergestellt. Die **HELIKA**®-Edelstahlspülen sind aus 1-2 mm dickem Stahl gefertigt, der Stabilität und Widerstandsfähigkeit gegen Dellen gewährleistet. Die satinierte Oberfläche ermöglicht eine mühelose Reinigung.

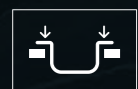

TOPMOUNTED
MONTUOJAMA ANT STALVIRŠIO
EINBAU

AIRA | LUNA | TERRA



UNDERMOUNTED
MONTUOJAMA PO STALVIRŠIU
UNTERBAU

ENNA | DERA | NOVA



HELIKA®
Inspired by slow living



SATIN BRUSHED SURFACE
SATINO ŠLIFUOTA DANGA
SATINIERTE OBERFLÄCHE



STAINLESS STEEL STRAINER
NERŪDIJANČIO PLIENO VENTILIS
EDELSTAHL-SIEBKORB



STAINLESS STEEL THICKNESS: 1-2 mm
NERŪDIJANČIO PLIENO STORIS: 1-2 mm
EDELSTAHLDICKE: 1-2 mm



R10 CORNER
R10 KAMPAS
R10-ECKE



QUALITY STEEL
PLIENO KOKYBĖ
QUALITÄTSSTAHL



SOUND INSULATION
GARSO IZOLIACIJA
GERÄUSCHDÄMPFUNG



DURABILITY
ILGAAMŽIŠKUMAS
LANGLEBIG

STAINLESS STEEL SINKS

SYMBOLS / SIMBOLIAI / SYMBOLE



AISI304 stainless steel
AISI304 nerūdijantis plienas
Edelstahl AISI304



Tempered glass thickness: 8 mm
Grūdinto stiklo storis: 8 mm
Dicke des gehärteten Glases: 8 mm



Satin brushed surface
Satino šlifauta danga
Satinierte Oberfläche



PVD surface
PVD danga
PVD-Beschichtung



Sandblasting surface
Sandblasting danga
Gesandstrahlte Oberfläche



Stainless steel thickness
Nerūdijančio plieno storis
Edelstahldicke



Stainless steel thickness
Nerūdijančio plieno storis
Edelstahldicke

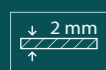

Stainless steel thickness
Nerūdijančio plieno storis
Edelstahldicke



Nano coating
Nanodanga
Nano-Oberfläche

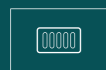

Rectangular overflow
Stačiakampio formos persipylimas
Rechteckiger Überlauf



Rectangular overflow
Stačiakampio formos persipylimas
Rechteckiger Überlauf



Mounting type: Topmounted
Montavimo tipas: ant stalviršio
Einbauart: Einbau



Mounting type: Undermounted
Montavimo tipas: po stalviršiu
Einbauart: Unterbau



R10 corner
R10 kampas
R10-Ecke



Factory-made holes (1 hole)
Gamyklinės skylės (1 skylė)
Vom Werk vorgefertigte Löcher (1 Loch)



Factory-made holes (2 holes)
Gamyklinės skylės (2 skylės)
Vom Werk vorgefertigte Löcher (2 Löcher)

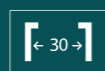

Cabinet size: 30 cm
Spintelės plotis: 30 cm
Schrankgröße: 30 cm

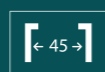

Cabinet size: 45 cm
Spintelės plotis: 45 cm
Schrankgröße: 45 cm

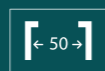

Cabinet size: 50 cm
Spintelės plotis: 50 cm
Schrankgröße: 50 cm

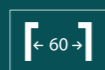

Cabinet size: 60 cm
Spintelės plotis: 60 cm
Schrankgröße: 60 cm

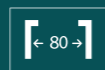

Cabinet size: 80 cm
Spintelės plotis: 80 cm
Schrankgröße: 80 cm



5-year warranty
5 metų garantija
5 Jahre Garantie

COLOURS SPALVOS / FARBEN

STEEL SURFACE / PLIENO PAVIRŠIUS / EDELSTAHL OBERFLÄCHE

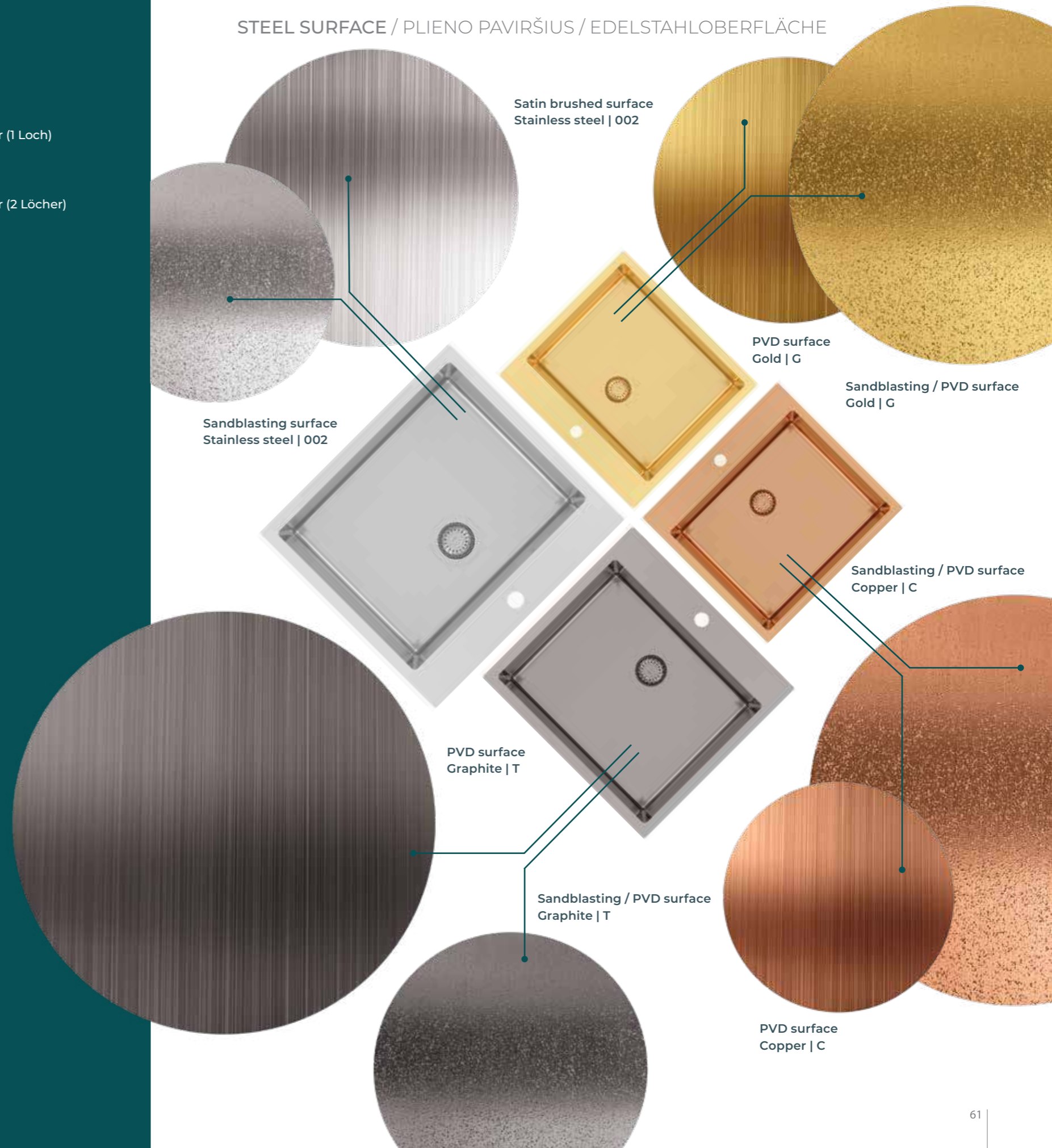

Satin brushed surface
Stainless steel | 002

Sandblasting surface
Stainless steel | 002

PVD surface
Gold | G

Sandblasting / PVD surface
Gold | G

Sandblasting / PVD surface
Copper | C

PVD surface
Graphite | T

Sandblasting / PVD surface
Graphite | T

PVD surface
Copper | C

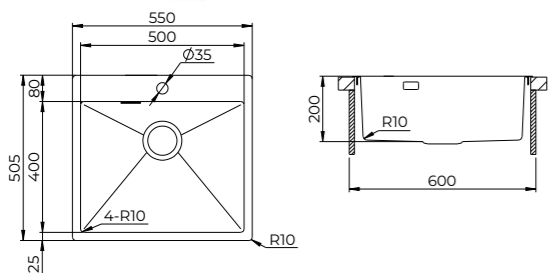

TERRA100N

Topmounted
Iš viršaus
Einbau

Installation type
Montavimo būdas
Einbauart

550 x 505 mm

Sink dimensions
Plautuvės matmenys
Abmessungen der Spüle

500 x 400 x 200 mm

Bowl dimensions
Dubens matmenys
Abmessungen des Beckens

600 mm

Min. cabinet size
Minimalus spintelės plotis
Min. Schrankgröße

SS-001V nano or / arba / oder
SS-001V-C nano or / arba / oder
SS-001V-G nano or / arba / oder
SS-001V-T nano

Supplied with
Komplekte
Enthalten

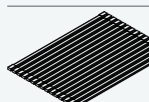

RM-2845
RM-2845-C
RM-2845-G
RM-2845-T

Recommended accessories
Rekomenduojami aksesuarai
Empfohlenes Zubehör

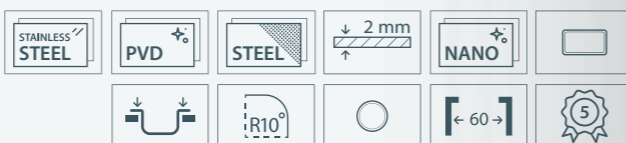

60

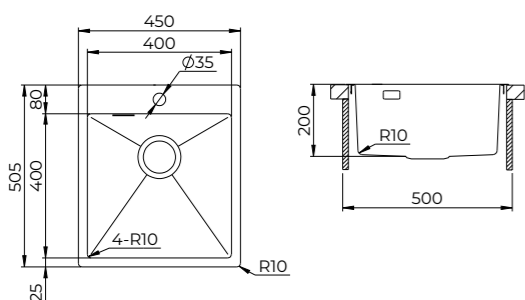

TERRA100X

Topmounted
Iš viršaus
Einbau

Installation type
Montavimo būdas
Einbauart

450 x 505 mm

Sink dimensions
Plautuvės matmenys
Abmessungen der Spüle

400 x 400 x 200 mm

Bowl dimensions
Dubens matmenys
Abmessungen des Beckens

500 mm

Min. cabinet size
Minimalus spintelės plotis
Min. Schrankgröße

SS-001V nano or / arba / oder
SS-001V-C nano or / arba / oder
SS-001V-G nano or / arba / oder
SS-001V-T nano

Supplied with
Komplekte
Enthalten

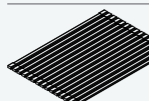

RM-2845
RM-2845-C
RM-2845-G
RM-2845-T

Recommended accessories
Rekomenduojami aksesuarai
Empfohlenes Zubehör

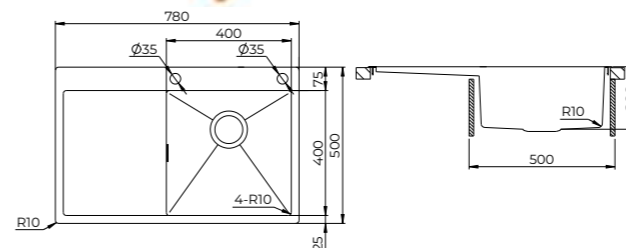
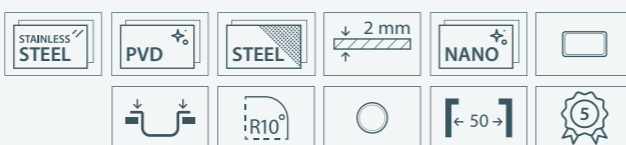

TERRA101N-L|R

Topmounted
Iš viršaus
Einbau

Installation type
Montavimo būdas
Einbauart

780 x 505 mm

Sink dimensions
Plautuvės matmenys
Abmessungen der Spüle

400 x 400 x 200 mm

Bowl dimensions
Dubens matmenys
Abmessungen des Beckens

500 mm

Min. cabinet size
Minimalus spintelės plotis
Min. Schrankgröße

SS-001V nano or / arba / oder
SS-001V-C nano or / arba / oder
SS-001V-G nano or / arba / oder
SS-001V-T nano

DH-002 or / arba / oder
DH-C or / arba / oder
DH-G or / arba / oder
DH-T

Supplied with
Komplekte
Enthalten

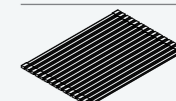

RM-2845
RM-2845-C
RM-2845-G
RM-2845-T

Recommended accessories
Rekomenduojami aksesuarai
Empfohlenes Zubehör

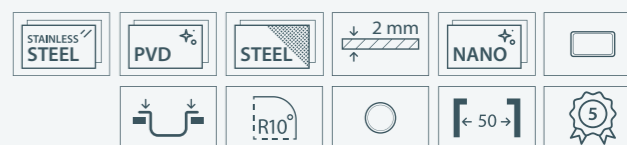

50

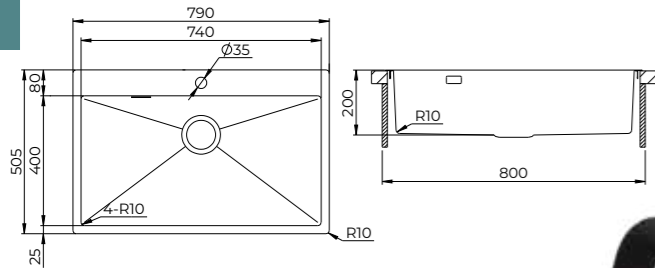

TERRA100M

Topmounted
Iš viršaus
Einbau

Installation type
Montavimo būdas
Einbaut

790 x 505 mm

Sink dimensions
Plautuvės matmenys
Abmessungen der Spüle

740 x 400 x 200 mm

Bowl dimensions
Dubens matmenys
Abmessungen des Beckens

800 mm

Min. cabinet size
Minimalus spintelės plotis
Min. Schrankgröße

SS-001V nano or / arba / oder
SS-001V-C nano or / arba / oder
SS-001V-G nano or / arba / oder
SS-001V-T nano

Supplied with
Komplekte
Enthalten

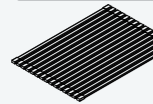

RM-2845
RM-2845-C
RM-2845-G
RM-2845-T

Recommended accessories
Rekomenduojami aksesuarai
Empfohlenes Zubehör

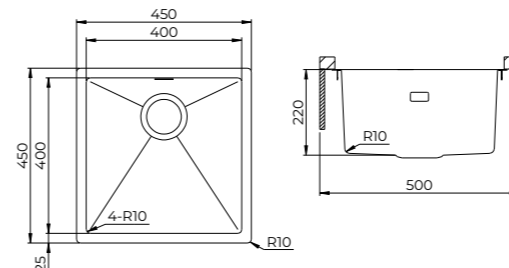
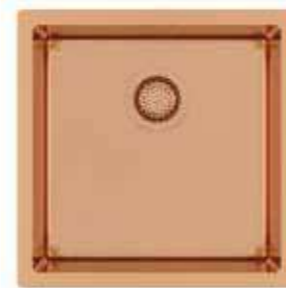
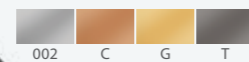
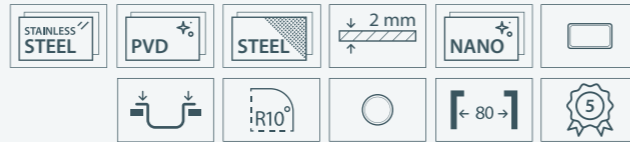

NOVA100X

Undermounted
Iš apačios
Unterbau

Installation type
Montavimo būdas
Einbaut

450 x 450 mm

Sink dimensions
Plautuvės matmenys
Abmessungen der Spüle

400 x 400 x 220 mm

Bowl dimensions
Dubens matmenys
Abmessungen des Beckens

500 mm

Min. cabinet size
Minimalus spintelės plotis
Min. Schrankgröße

SS-001V nano or / arba / oder
SS-001V-C nano or / arba / oder
SS-001V-G nano or / arba / oder
SS-001V-T nano

Supplied with
Komplekte
Enthalten

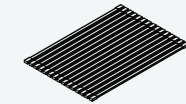

RM-2845
RM-2845-C
RM-2845-G
RM-2845-T

Recommended accessories
Rekomenduojami aksesuarai
Empfohlenes Zubehör

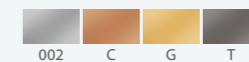
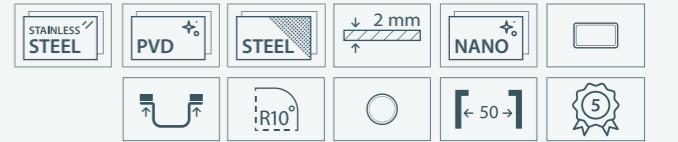

NOVA100L-C / 7763-C /
RM-2845-C / DH-C

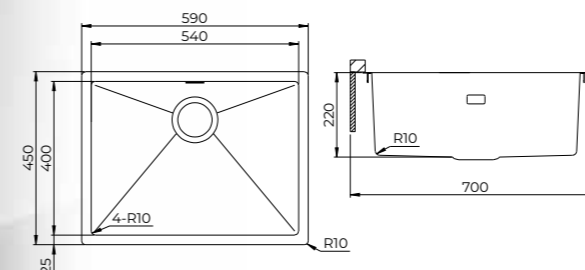
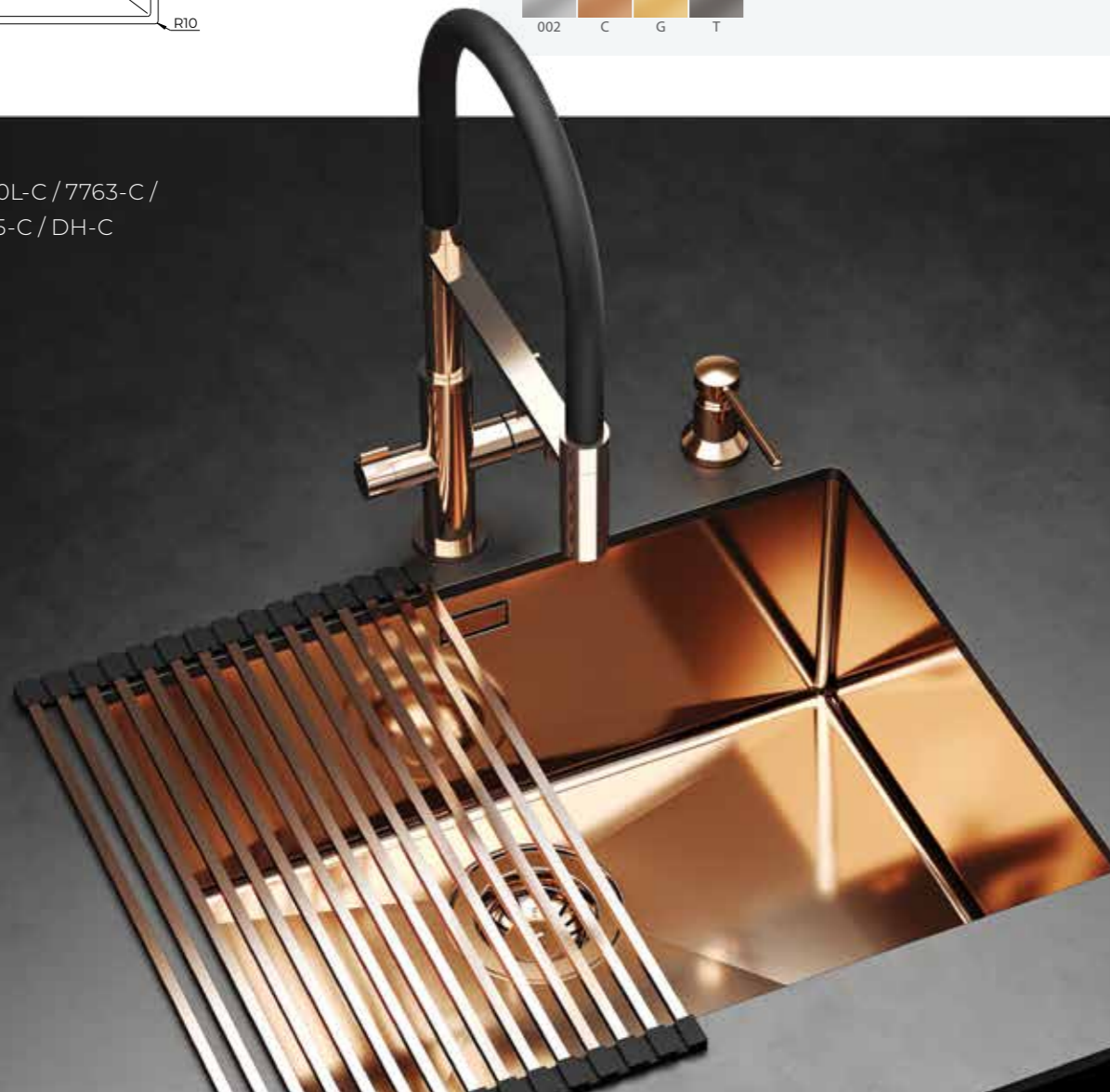

NOVA100L

Undermounted
Iš apačios
Unterbau

Installation type
Montavimo būdas
Einbaut

590 x 450 mm

Sink dimensions
Plautuvės matmenys
Abmessungen der Spüle

540 x 400 x 220 mm

Bowl dimensions
Dubens matmenys
Abmessungen des Beckens

700 mm

Min. cabinet size
Minimalus spintelės plotis
Min. Schrankgröße

SS-001V nano or / arba / oder
SS-001V-C nano or / arba / oder
SS-001V-G nano or / arba / oder
SS-001V-T nano

Supplied with
Komplekte
Enthalten

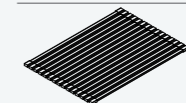

RM-2845
RM-2845-C
RM-2845-G
RM-2845-T

Recommended accessories
Rekomenduojami aksesuarai
Empfohlenes Zubehör

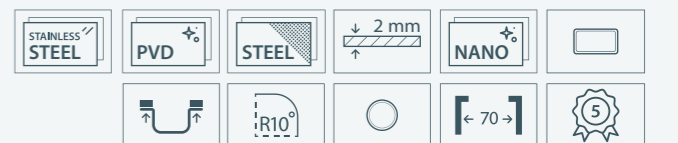

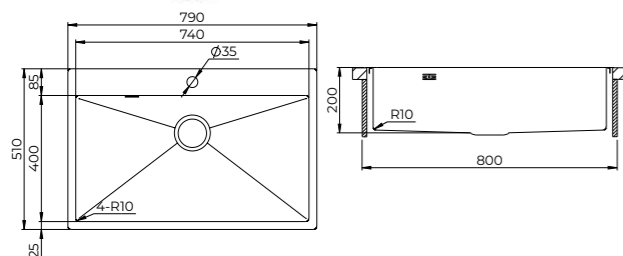

AIRA AIR100M

Topmounted
Iš viršaus
Einbau

Installation type
Montavimo būdas
Einbauart

790 x 510 mm

Sink dimensions
Plautuvės matmenys
Abmessungen der Spüle

740 x 400 x 200 mm

Bowl dimensions
Dubens matmenys
Abmessungen des Beckens

800 mm

Min. cabinet size
Minimalus spintelės plotis
Min. Schrankgröße

SS-001V or / arba / oder
SS-001V-C or / arba / oder
SS-001V-G or / arba / oder
SS-001V-T

Supplied with
Komplekte
Enthalten

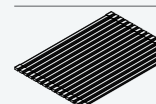

RM-2845
RM-2845-C
RM-2845-G
RM-2845-T

Recommended accessories
Rekomenduojami aksesuarai
Empfohlenes Zubehör

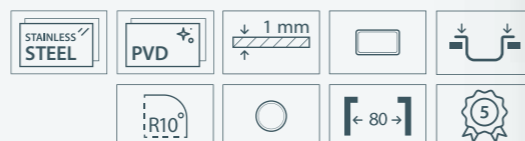

80

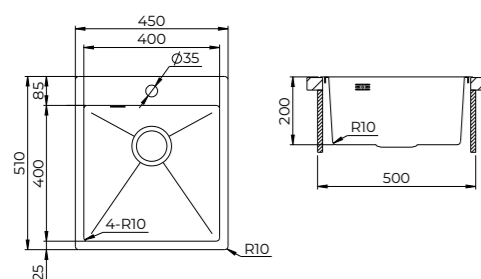

AIRA AIR100X

Topmounted
Iš viršaus
Einbau

Installation type
Montavimo būdas
Einbauart

450 x 510 mm

Sink dimensions
Plautuvės matmenys
Abmessungen der Spüle

400 x 400 x 200 mm

Bowl dimensions
Dubens matmenys
Abmessungen des Beckens

500 mm

Min. cabinet size
Minimalus spintelės plotis
Min. Schrankgröße

SS-001V or / arba / oder
SS-001V-C or / arba / oder
SS-001V-G or / arba / oder
SS-001V-T

Supplied with
Komplekte
Enthalten

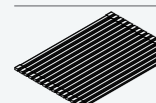

RM-2845
RM-2845-C
RM-2845-G
RM-2845-T

Recommended accessories
Rekomenduojami aksesuarai
Empfohlenes Zubehör

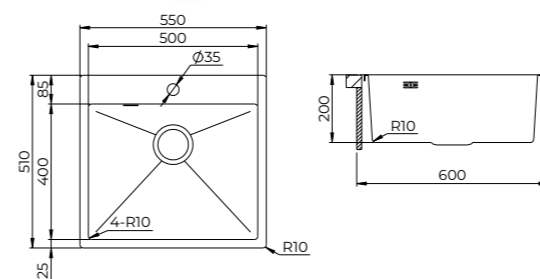
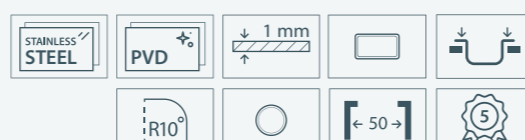

AIRA AIR100N

Topmounted
Iš viršaus
Einbau

Installation type
Montavimo būdas
Einbauart

550 x 510 mm

Sink dimensions
Plautuvės matmenys
Abmessungen der Spüle

500 x 400 x 200 mm

Bowl dimensions
Dubens matmenys
Abmessungen des Beckens

600 mm

Min. cabinet size
Minimalus spintelės plotis
Min. Schrankgröße

SS-001V or / arba / oder
SS-001V-C or / arba / oder
SS-001V-G or / arba / oder
SS-001V-T

Supplied with
Komplekte
Enthalten

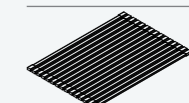

RM-2845
RM-2845-C
RM-2845-G
RM-2845-T

Recommended accessories
Rekomenduojami aksesuarai
Empfohlenes Zubehör

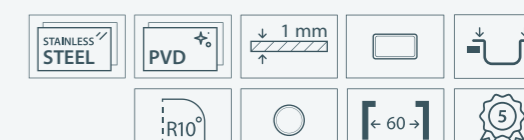

60



DERA DER100L

Undermounted
Iš apačios
Unterbau

Installation type
Montavimo būdas
Einbauart

550 x 450 mm

Sink dimensions
Plautuvės matmenys
Abmessungen der Spüle

500 x 400 x 200 mm

Bowl dimensions
Dubens matmenys
Abmessungen des Beckens

600 mm

Min. cabinet size
Minimalus spintelės plotis
Min. Schrankgröße

SS-001V or / arba / oder
SS-001V-C or / arba / oder
SS-001V-G or / arba / oder
SS-001V-T

Supplied with
Komplekte
Enthalten

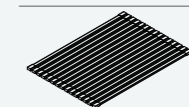

RM-2845
RM-2845-C
RM-2845-G
RM-2845-T

Recommended accessories
Rekomenduojami aksesuarai
Empfohlenes Zubehör

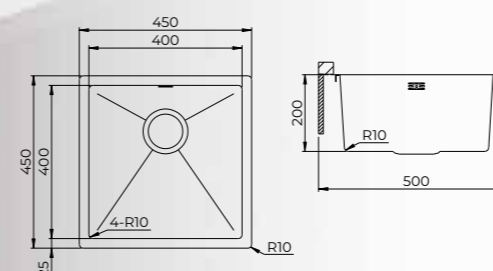
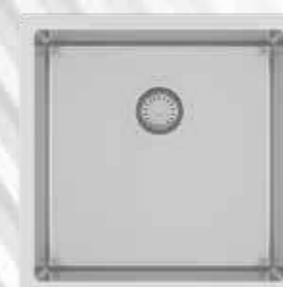
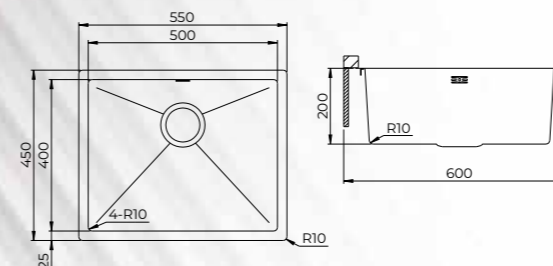
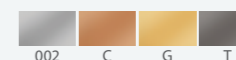

DERA DER100X

Undermounted
Iš apačios
Unterbau

Installation type
Montavimo būdas
Einbauart

450 x 450 mm

Sink dimensions
Plautuvės matmenys
Abmessungen der Spüle

400 x 400 x 200 mm

Bowl dimensions
Dubens matmenys
Abmessungen des Beckens

500 mm

Min. cabinet size
Minimalus spintelės plotis
Min. Schrankgröße

SS-001V or / arba / oder
SS-001V-C or / arba / oder
SS-001V-G or / arba / oder
SS-001V-T

Supplied with
Komplekte
Enthalten

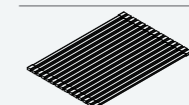

RM-2845
RM-2845-C
RM-2845-G
RM-2845-T

Recommended accessories
Rekomenduojami aksesuarai
Empfohlenes Zubehör

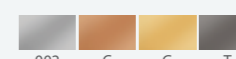

DER100L-T / 2663L-T /
RM-2845-T / DH-T

45

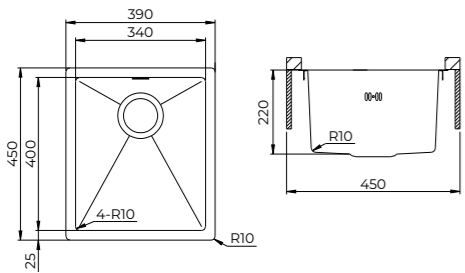

ENNA ENN100M

Undermounted
Iš apačios
Unterbau

Installation type
Montavimo būdas
Einbauart

390 x 450 mm

Sink dimensions
Plautuvės matmenys
Abmessungen der Spüle

340 x 400 x 220 mm

Bowl dimensions
Dubens matmenys
Abmessungen des Beckens

450 mm

Min. cabinet size
Minimalus spintelės plotis
Min. Schrankgröße

AQF-001V

Supplied with
Komplekte
Enthalten

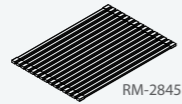

Recommended accessories
Rekomenduojami aksesuarai
Empfohlenes Zubehör

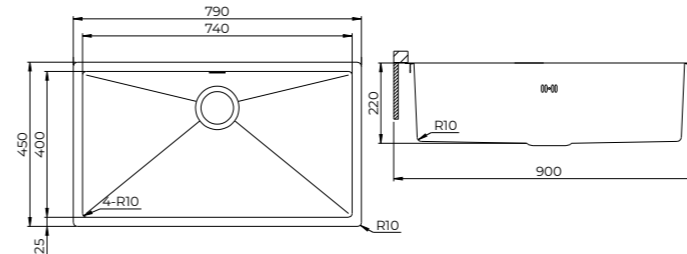

ENNA ENN100B

Undermounted
Iš apačios
Unterbau

Installation type
Montavimo būdas
Einbauart

790 x 450 mm

Sink dimensions
Plautuvės matmenys
Abmessungen der Spüle

740 x 400 x 220 mm

Bowl dimensions
Dubens matmenys
Abmessungen des Beckens

900 mm

Min. cabinet size
Minimalus spintelės plotis
Min. Schrankgröße

AQF-001V

Supplied with
Komplekte
Enthalten

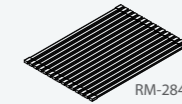

Recommended accessories
Rekomenduojami aksesuarai
Empfohlenes Zubehör



30

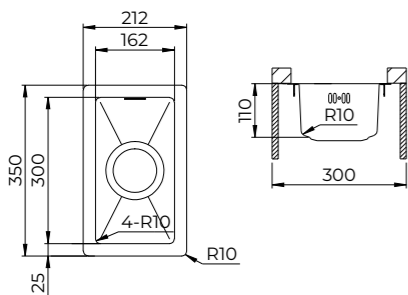

ENNA ENN100S

Undermounted
Iš apačios
Unterbau

Installation type
Montavimo būdas
Einbauart

212 x 350 mm

Sink dimensions
Plautuvės matmenys
Abmessungen der Spüle

162 x 300 x 110 mm

Bowl dimensions
Dubens matmenys
Abmessungen des Beckens

300 mm

Min. cabinet size
Minimalus spintelės plotis
Min. Schrankgröße

AQF-001V

Supplied with
Komplekte
Enthalten

Recommended accessories
Rekomenduojami aksesuarai
Empfohlenes Zubehör

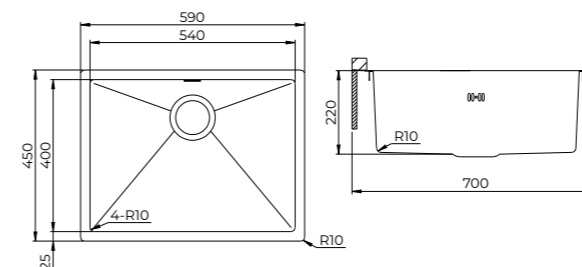

ENNA ENN100L

Undermounted
Iš apačios
Unterbau

Installation type
Montavimo būdas
Einbauart

590 x 450 mm

Sink dimensions
Plautuvės matmenys
Abmessungen der Spüle

540 x 400 x 220 mm

Bowl dimensions
Dubens matmenys
Abmessungen des Beckens

700 mm

Min. cabinet size
Minimalus spintelės plotis
Min. Schrankgröße

AQF-001V

Supplied with
Komplekte
Enthalten

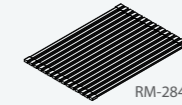

Recommended accessories
Rekomenduojami aksesuarai
Empfohlenes Zubehör

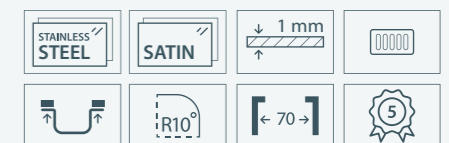

90

70

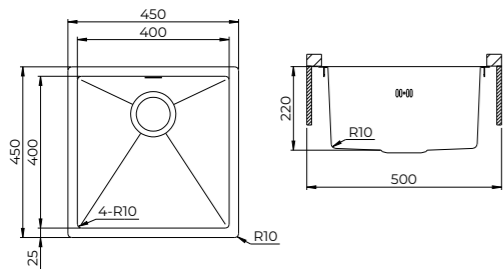

ENNA ENN100X

Undermounted
Iš apačios
Unterbau

Installation type
Montavimo būdas
Einbauart

450 x 450 mm

Sink dimensions
Plautuvės matmenys
Abmessungen der Spüle

400 x 400 x 220 mm

Bowl dimensions
Dubens matmenys
Abmessungen des Beckens

500 mm

Min. cabinet size
Minimalus spintelės plotis
Min. Schrankgröße

AQF-001V

Supplied with
Komplekte
Enthalten

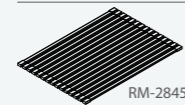

Recommended accessories
Rekomenduojami aksesuarai
Empfohlenes Zubehör

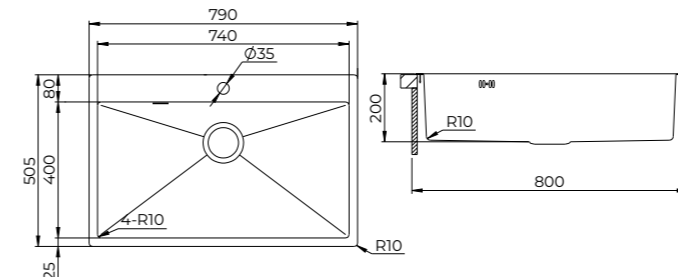

LUNA LUN100M

Topmounted
Iš viršaus
Einbau

Installation type
Montavimo būdas
Einbauart

790 x 505 mm

Sink dimensions
Plautuvės matmenys
Abmessungen der Spüle

740 x 400 x 200 mm

Bowl dimensions
Dubens matmenys
Abmessungen des Beckens

800 mm

Min. cabinet size
Minimalus spintelės plotis
Min. Schrankgröße

AQF-001V

Supplied with
Komplekte
Enthalten

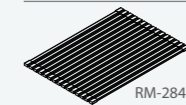

Recommended accessories
Rekomenduojami aksesuarai
Empfohlenes Zubehör

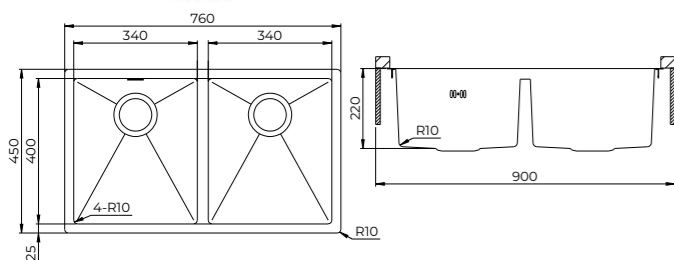
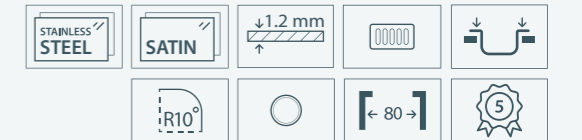

ENNA ENN200L

Undermounted
Iš apačios
Unterbau

Installation type
Montavimo būdas
Einbauart

760 x 450 mm

Sink dimensions
Plautuvės matmenys
Abmessungen der Spüle

340 x 400 x 220 mm
340 x 400 x 220 mm

Bowl dimensions
Dubens matmenys
Abmessungen des Beckens

900 mm

Min. cabinet size
Minimalus spintelės plotis
Min. Schrankgröße

AQF-005V

Supplied with
Komplekte
Enthalten

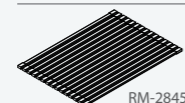

Recommended accessories
Rekomenduojami aksesuarai
Empfohlenes Zubehör

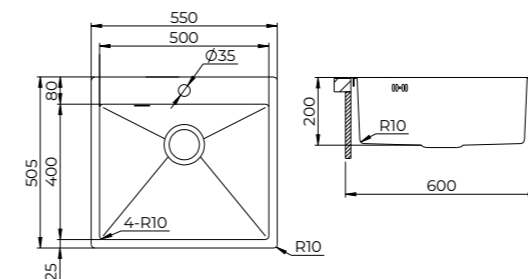
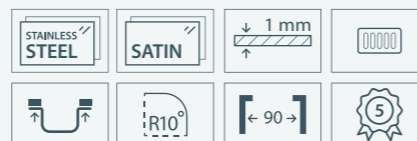

LUNA LUN100N

Topmounted
Iš viršaus
Einbau

Installation type
Montavimo būdas
Einbauart

550 x 505 mm

Sink dimensions
Plautuvės matmenys
Abmessungen der Spüle

500 x 400 x 200 mm

Bowl dimensions
Dubens matmenys
Abmessungen des Beckens

600 mm

Min. cabinet size
Minimalus spintelės plotis
Min. Schrankgröße

AQF-001V

Supplied with
Komplekte
Enthalten

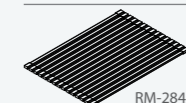

Recommended accessories
Rekomenduojami aksesuarai
Empfohlenes Zubehör



LUNA LUN100X

Topmounted
Iš viršaus
Einbau

Installation type
Montavimo būdas
Einbauart

450 x 505 mm

Sink dimensions
Plautuvės matmenys
Abmessungen der Spüle

400 x 400 x 200 mm

Bowl dimensions
Dubens matmenys
Abmessungen des Beckens

500 mm

Min. cabinet size
Minimalus spintelės plotis
Min. Schrankgröße

AQF-001V

Supplied with
Komplekte
Enthalten

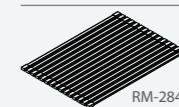

Recommended accessories
Rekomenduojami aksesuarai
Empfohlenes Zubehör

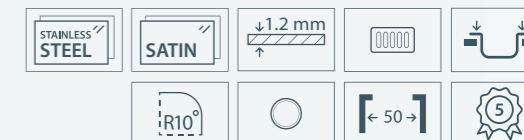

002

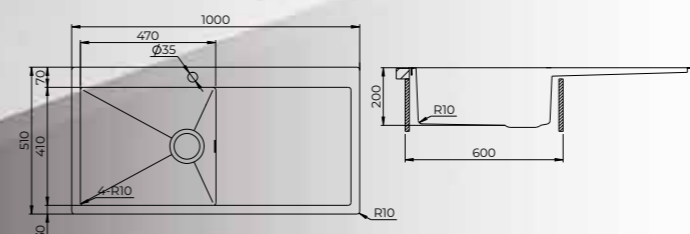
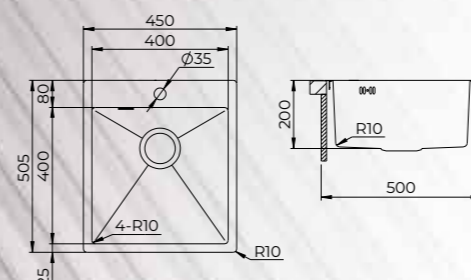

LUNA LUN101M-R/L

Topmounted
Iš viršaus
Einbau

Installation type
Montavimo būdas
Einbauart

1000 x 510 mm

Sink dimensions
Plautuvės matmenys
Abmessungen der Spüle

470 x 410 x 200 mm

Bowl dimensions
Dubens matmenys
Abmessungen des Beckens

600 mm

Min. cabinet size
Minimalus spintelės plotis
Min. Schrankgröße

AQF-001V

Supplied with
Komplekte
Enthalten

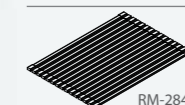

Recommended accessories
Rekomenduojami aksesuarai
Empfohlenes Zubehör

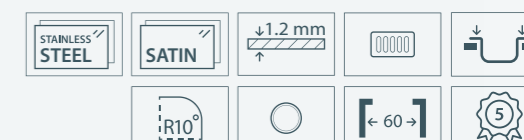

002



LUNA LUN151M-L|R

Topmounted
Iš viršaus
Einbau

Installation type
Montavimo būdas
Einbauart

1000 x 510 mm

Sink dimensions
Plautuvės matmenys
Abmessungen der Spüle

340 x 410 x 200 mm
170 x 410 x 128 mm

Bowl dimensions
Dubens matmenys
Abmessungen des Beckens

600 mm

Min. cabinet size
Minimalus spintelės plotis
Min. Schrankgröße

AQF-005V

Supplied with
Komplekte
Enthalten

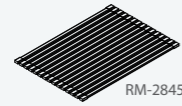

Recommended accessories
Rekomenduojami aksesuarai
Empfohlenes Zubehör

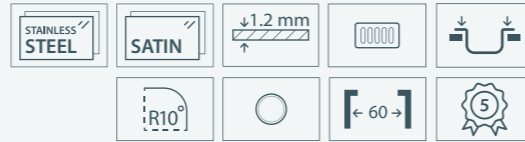

002

60

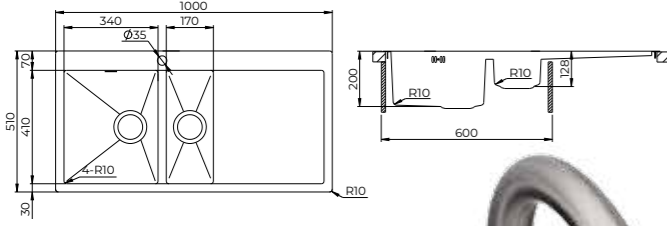

LUNA LUN151N-L|R

Topmounted
Iš viršaus
Einbau

Installation type
Montavimo būdas
Einbauart

780 x 500 mm

Sink dimensions
Plautuvės matmenys
Abmessungen der Spüle

340 x 400 x 200 mm
170 x 400 x 128 mm

Bowl dimensions
Dubens matmenys
Abmessungen des Beckens

600 mm

Min. cabinet size
Minimalus spintelės plotis
Min. Schrankgröße

AQF-005V

Supplied with
Komplekte
Enthalten

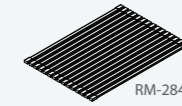

Recommended accessories
Rekomenduojami aksesuarai
Empfohlenes Zubehör

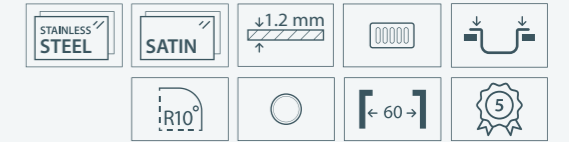

002

60

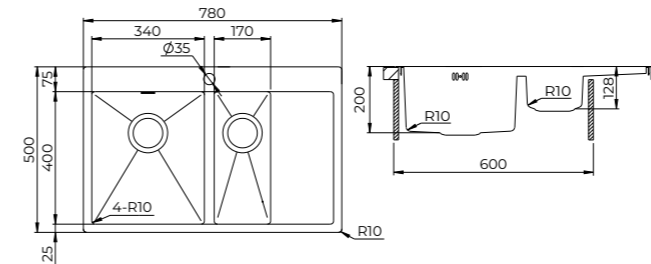

LUN151M-L / 7723-002



LUNA LUN101N-L|R

Topmounted
Iš viršaus
Einbau

Installation type
Montavimo būdas
Einbauart

780 x 500 mm

Sink dimensions
Plautuvės matmenys
Abmessungen der Spüle

400 x 400 x 200 mm

Bowl dimensions
Dubens matmenys
Abmessungen des Beckens

500 mm

Min. cabinet size
Minimalus spintelės plotis
Min. Schrankgröße

AQF-001V

Supplied with
Komplekte
Enthalten

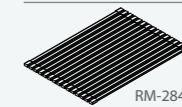

Recommended accessories
Rekomenduojami aksesuarai
Empfohlenes Zubehör



002

50

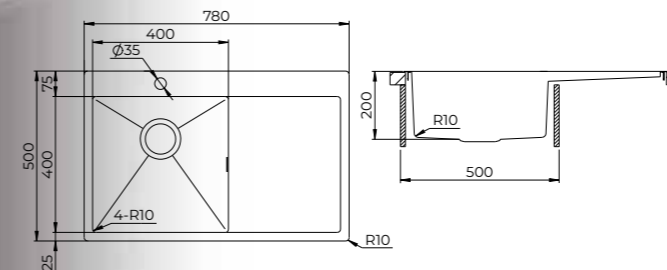

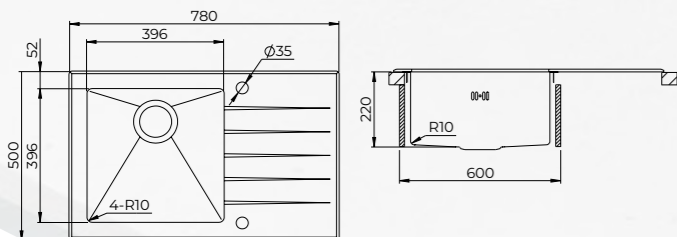
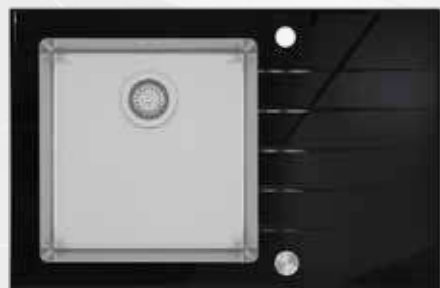

**STAINLESS STEEL AND TEMPERED BLACK GLASS
ENG100XB-L|R**

Topmounted
Iš viršaus
Einbau

Installation type
Montavimo būdas
Einbauart

780 x 500 mm

Sink dimensions
Plautuvės matmenys
Abmessungen der Spüle

396 x 396 x 220 mm

Bowl dimensions
Dubens matmenys
Abmessungen des Beckens

600 mm

Min. cabinet size
Minimalus spintelės plotis
Min. Schrankgröße

AQL-SS-001V

Supplied with
Komplekte
Enthalten

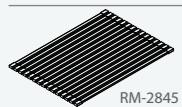

RM-2845

Recommended accessories
Rekomenduojami aksesuarai
Empfohlenes Zubehör



002



ENG100XB-R / 7763-001 /
AQL-SS-001V

FAUCETS

MAIŠYTUVAI / ARMATUREN

Discover a wide selection of brass or stainless steel faucets in various shapes and styles, from classic to modern, that complement your home interior. You can customise your faucets with different colours and functions that meet your preferences and needs. Make your kitchen area colourful and functional with **HELIKA®** kitchen faucets!

Susipažinkite su plačiu įvairių formų žalvarinių arba nerūdijančio plieno maišytuvų pasirinkimu nuo klasikinio iki modernaus. Išsirinkite bet kuriam interjerui! Derinkite ir pritaikykite įvairių spalvų bei funkcijų maišytuvus prie savo poreikių ir norų! Tegul jūsų virtuvė bus spalvinga ir funkcionali su **HELIKA®** virtuvės maišytuvais!

Entdecken Sie eine große Auswahl an Armaturen aus Messing oder Edelstahl in verschiedenen Formen und Stilen, von klassisch bis modern, die Ihre Einrichtung ergänzen. Sie können Ihre Armaturen mit verschiedenen Farben und Funktionen anpassen, die Ihren Vorlieben und Bedürfnissen entsprechen. Gestalten Sie Ihren Küchenbereich farbenfroh und funktional mit **HELIKA®** Küchenarmaturen!

COLLECTION | KOLEKCIJA | KOLLEKTION

AKVADUO | AKVADUO PLUS
AMBRA | COLOS
DOLUS | ECO | FLEXA
FORTE | FORTE ECO2 | GRATA
HERA | MATENO | MIRRUS
MODUS | MOJOSA | REGITO
RONDO | SABIA | SABIA ECO
SABIA GRACE | SABIADUO
SIGNA | SOIFOS | SUPRA
TURTL CANTUS | UNUS | VIDE

HELIKA®
Inspired by slow living







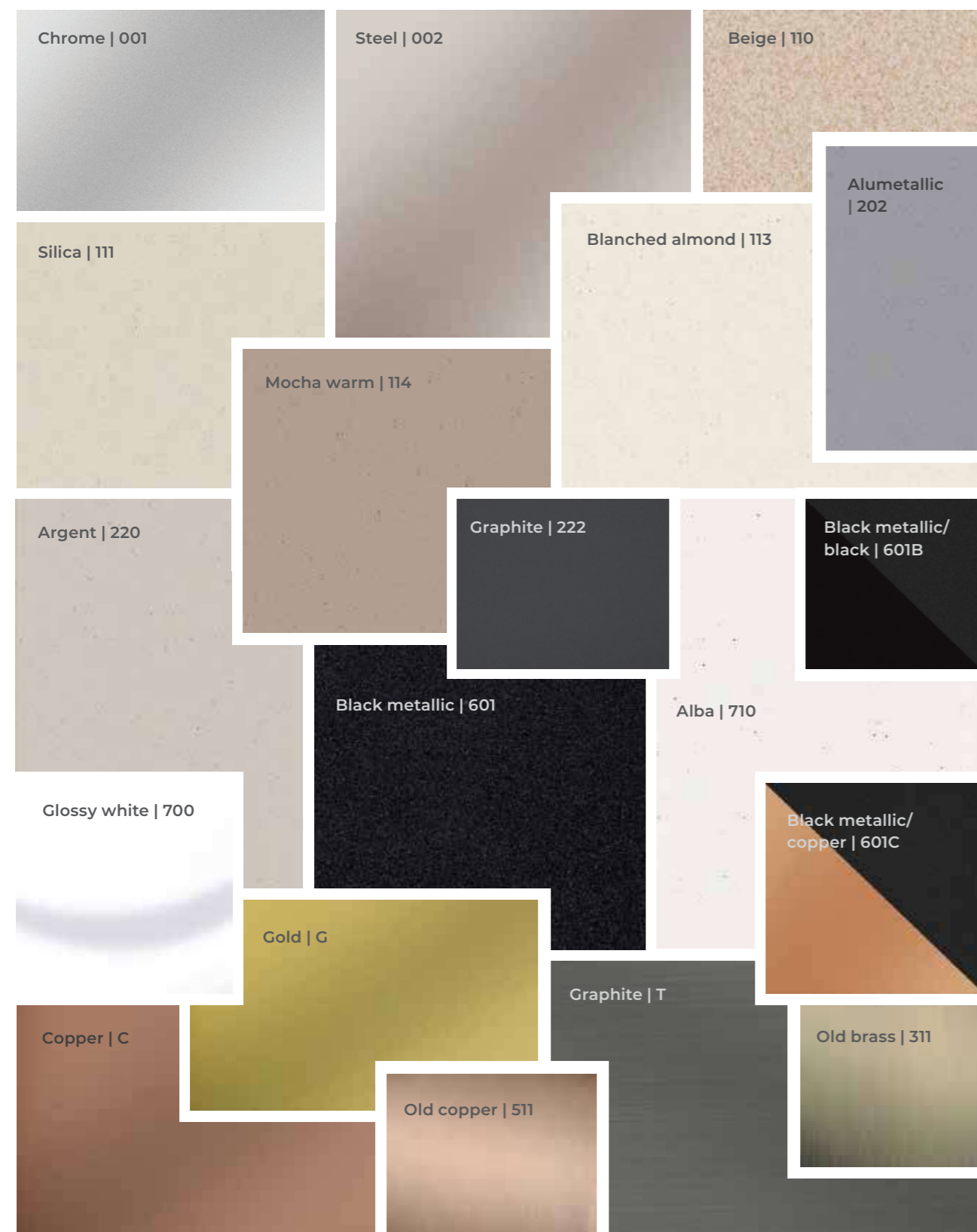









COLOURS SPALVOS / FARBEN

Faucet colours
Maišytuvų spalvos / Farben der Armaturen



FAUCETS MAIŠYTUVAI / ARMATUREN

SYMBOLS / SIMBOLIAI / SYMBOLE

-  Brass material
Žalvaris
Messing
-  Stainless steel material
Nerūdijantis plienas
Edelstahl
-  Neoperl aerator
Neoperl aeratorius
Neoperl-Belüfter
-  Ceramic cartridge 25 mm
Keramikinė kasetė 25 mm
Keramikkartusche 25 mm
-  Ceramic cartridge 28 mm
Keramikinė kasetė 28 mm
Keramikkartusche 28 mm
-  Ceramic cartridge 35 mm
Keramikinė kasetė 35 mm
Keramikkartusche 35 mm
-  Ceramic cartridge 40 mm
Keramikinė kasetė 40 mm
Keramikkartusche 40 mm
-  Brass cartridge
Žalvarinė kasetė
Messingkartusche
-  90-degree handle rotation
90 laipsnių rankenėlės pasukimo kampas
90-Grad Hebedrehung
-  45-degree handle rotation
45 laipsnių rankenėlės pasukimo kampas
45-Grad Hebedrehung
-  Filtered water function
Filtruoto vandens funkcija
Funktion für gefiltertes Wasser
-  Pull-down spout type
Žemyn ištraukiamo snapo tipas
Herunterziehbarer Auslauf
-  Pull-out spray spout type
Ištraukiamas dušo galvos snapo tipas
Herausziehbarer Sprühkopf
-  2-year warranty
2 metų garantija
2 Jahre Garantie
-  5-year warranty
5 metų garantija
5 Jahre Garantie



AKVADUO 2663L

Kitchen faucet
Virtuvės maišytuvas
Küchenarmatur

Dimensions
Matmenys / Abmessungen

242 x 306 mm

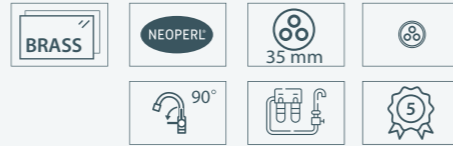
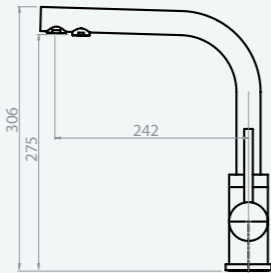

TERRA01N-R-G / 7003-G / RM-2845-G / DH-G



AMBRA 2813

Kitchen faucet
Virtuvės maišytuvas
Küchenarmatur

Dimensions
Matmenys / Abmessungen

195 x 267 mm

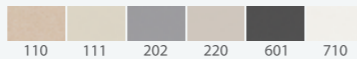
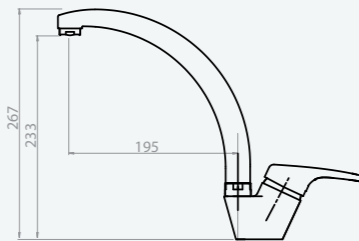

COLOS 7003

Pull-down kitchen faucet
Ištraukiamas virtuvės maišytuvas
Herunterziehbare Küchenarmatur

Dimensions
Matmenys / Abmessungen

220 x 467 mm

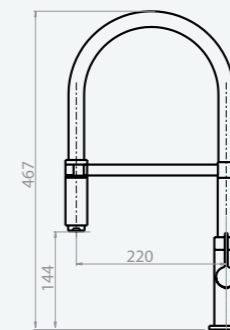
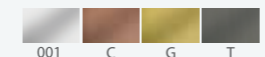

NEW



NEW



FLEXA 5543

Kitchen faucet
Virtuvės maišytuvas
Küchenarmatur

Dimensions
Matmenys / Abmessungen

215 x 379 mm

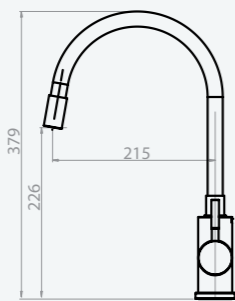



ECO 2561

Kitchen faucet
Virtuvės maišytuvas
Küchenarmatur

Dimensions
Matmenys / Abmessungen

230 x 125 mm

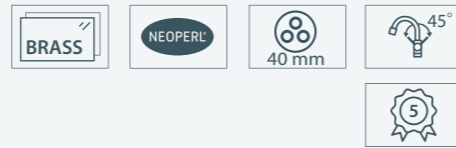
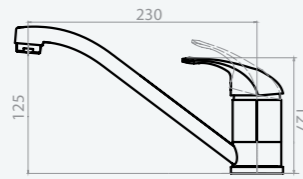

NEW

DOLUS 7783

Pull-out kitchen faucet
Virtuvės maišytuvas su ištraukiama dušo galva
Armatur mit herausziehbarem Sprühkopf

Dimensions
Matmenys / Abmessungen

225 x 316 mm

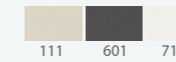
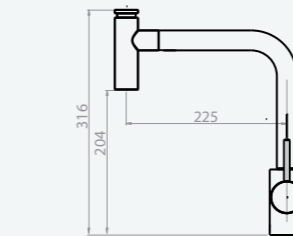

Forte 5553

Kitchen faucet
Virtuvės maišytuvas
Küchenarmatur

Dimensions
Matmenys / Abmessungen

180 x 273 mm

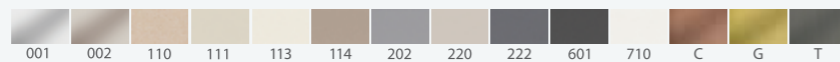
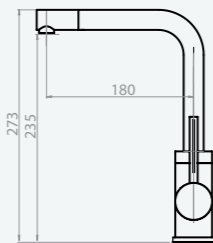

SQT105AWP-601 / 7783-601 / AQL-002V



FORTE 5553E2

Kitchen faucet
Virtuvės maišytuvas
Küchenarmatur

Dimensions
Matmenys / Abmessungen

226 x 303 mm

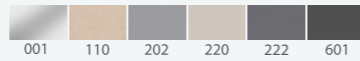
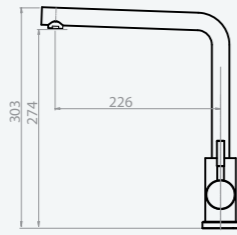

HERA 2473

Kitchen faucet
Virtuvės maišytuvas
Küchenarmatur

Dimensions
Matmenys / Abmessungen

186 x 274 mm

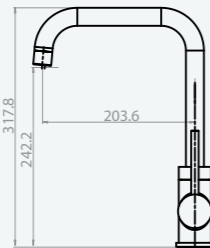
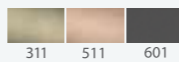
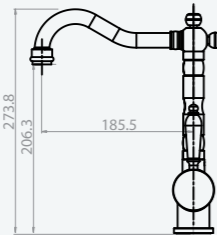

MIRRUS 5063

Kitchen faucet
Virtuvės maišytuvas
Küchenarmatur

Dimensions
Matmenys / Abmessungen

204 x 318 mm



LUN100M / 7723-002

GRATA 7723

Pull-down kitchen faucet
Ištraukiamas virtuvės maišytuvas
Herunterziehbare Küchenarmatur

Dimensions
Matmenys / Abmessungen

220 x 433 mm

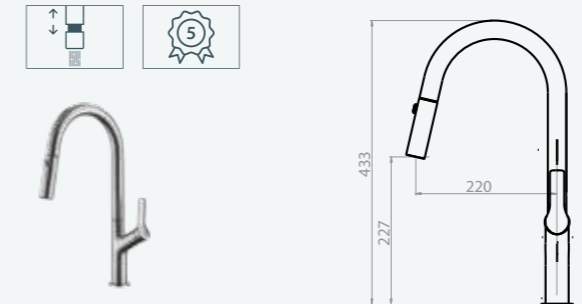



SQA104W-601 / 7023-601B / AQP-601



NEW

MATENO 7023

Pull-down kitchen faucet
Ištraukiamas virtuvės maišytuvas
Herunterziehbare Küchenarmatur

Dimensions
Matmenys / Abmessungen

243 x 427 mm

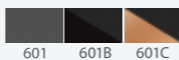
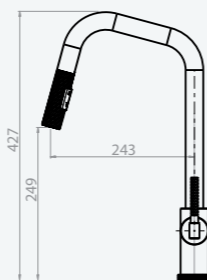
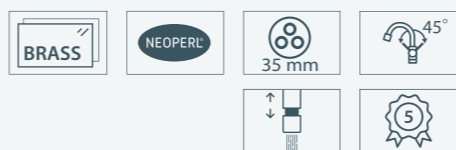

MODUS 2383

Pull-out kitchen faucet
Virtuvės maišytuvas su ištraukiama dušo galva
Armatur mit herausziehbarem Sprühkopf

Dimensions
Matmenys / Abmessungen

187 x 273 mm

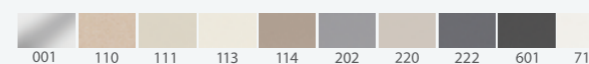
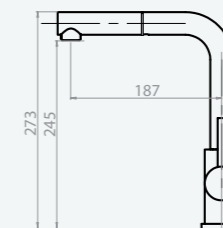

REGITO 2063

Kitchen faucet
Virtuvės maišytuvas
Küchenarmatur

Dimensions
Matmenys / Abmessungen

220 x 266 mm

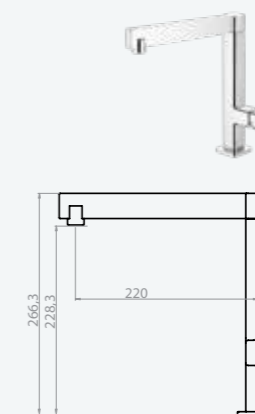

RONDO 2581

Pull-out kitchen faucet
Virtuvės maišytuvas su ištraukiama dušo galva
Armatur mit herausziehbarem Sprühkopf

Dimensions
Matmenys / Abmessungen

197 x 170 mm

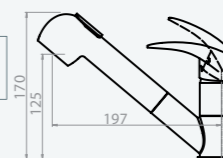
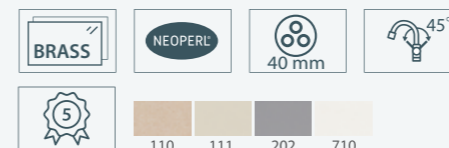

NEW



SABIA 5523

Kitchen faucet
Virtuvės maišytuvas
Küchenarmatur

Dimensions
Matmenys / Abmessungen

172 x 335 mm

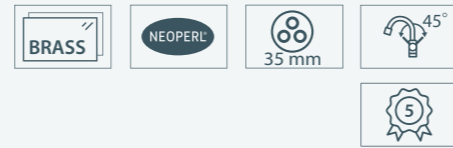
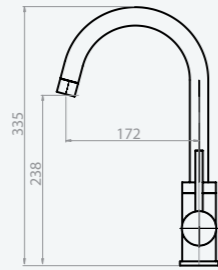

001 002 110 111 113 114 202 222 601 710

TURTL CANTUS 7083

Kitchen faucet
Virtuvės maišytuvas
Küchenarmatur

Dimensions
Matmenys / Abmessungen

200 x 292 mm

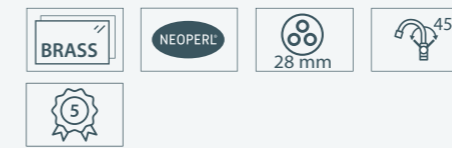
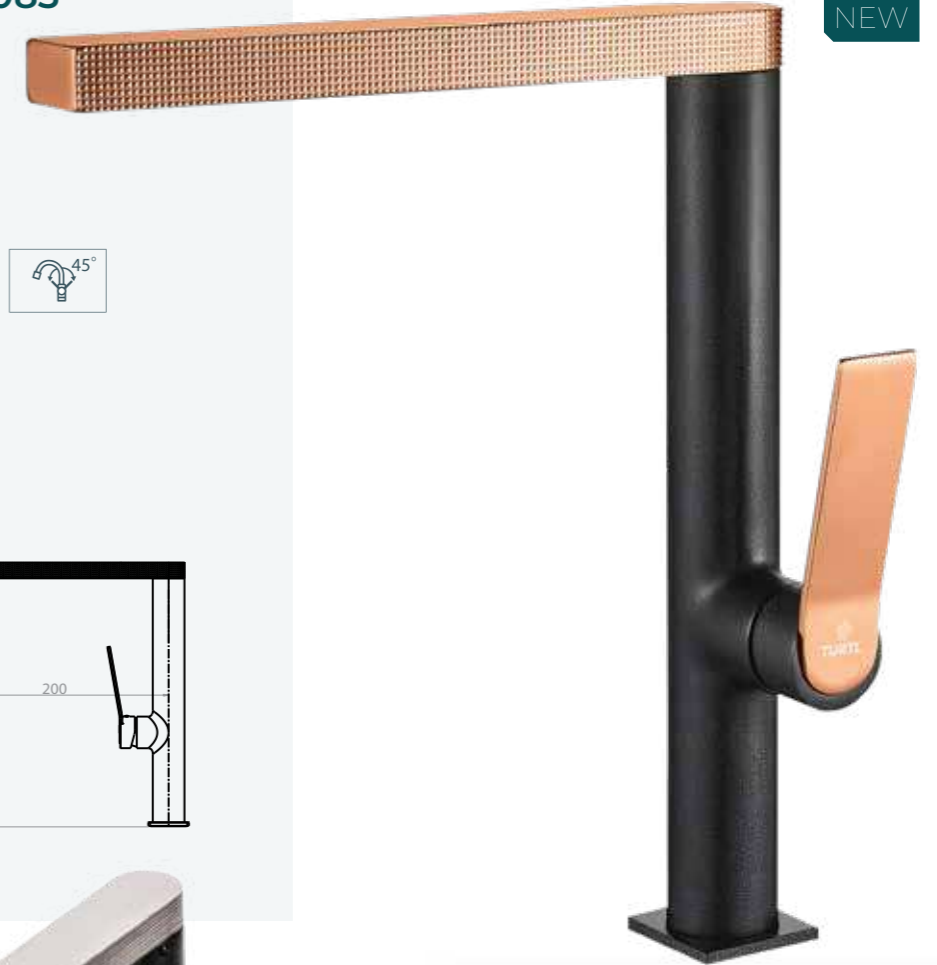

601 601C 710



SABIA ECO 5523E2

Kitchen faucet
Virtuvės maišytuvas
Küchenarmatur

Dimensions
Matmenys / Abmessungen

184 x 361 mm

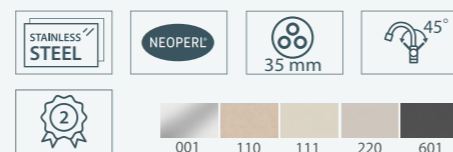

001 110 111 220 601



SABIA GRACE 5523JG

Kitchen faucet
Virtuvės maišytuvas
Küchenarmatur

Dimensions
Matmenys / Abmessungen

208 x 394 mm

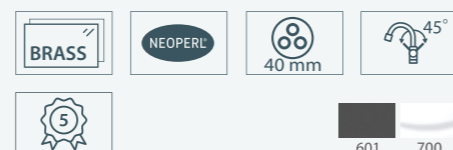

601 700



SQT101AW-601 / 7083-601 / RM-2845 / AQF-002V



TQL100W-601 / 7763-001 / AQP-601 / DTR-601CR

SABIADUO 2963

Kitchen faucet
Virtuvės maišytuvas
Küchenarmatur

Dimensions
Matmenys / Abmessungen

198 x 372 mm

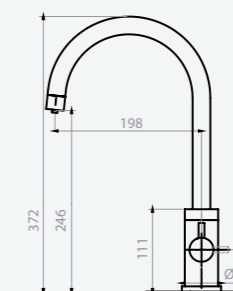

NEW

SOIFOS 7763

Pull-out kitchen faucet
Virtuvės maišytuvas su ištraukiama dušo galva
Armatur mit herausziehbarem Sprühkopf

Dimensions
Matmenys / Abmessungen

220 x 477 mm

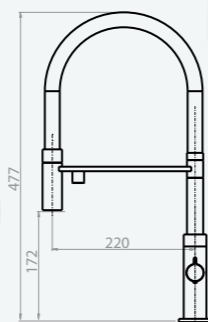
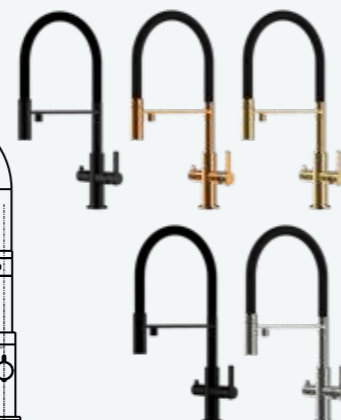
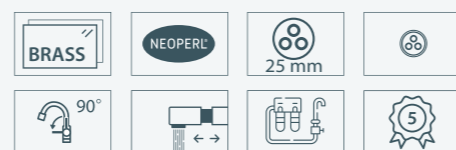

SIGNA 2083

Kitchen faucet
Virtuvės maišytuvas
Küchenarmatur

Dimensions
Matmenys / Abmessungen

195 x 307 mm

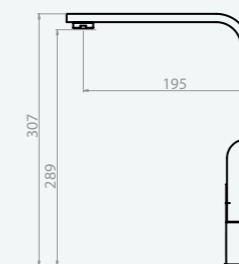

MOJOSA 7063

Pull-down kitchen faucet
Ištraukiamas virtuvės maišytuvas
Herunterziehbare Küchenarmatur

Dimensions
Matmenys / Abmessungen

218 x 437 mm

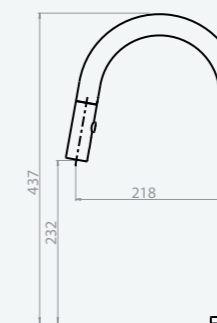
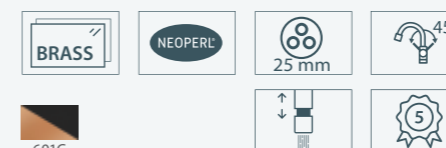

NEW

AKVADUO PLUS 2683

Pull-out kitchen faucet
Virtuvės maišytuvas su ištraukiama dušo galva
Armatur mit herausziehbarem Sprühkopf

Dimensions
Matmenys / Abmessungen

200 x 330 mm

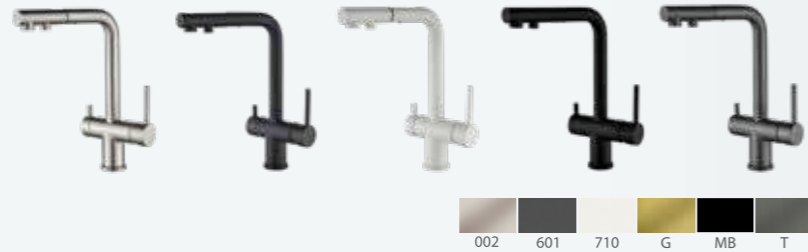
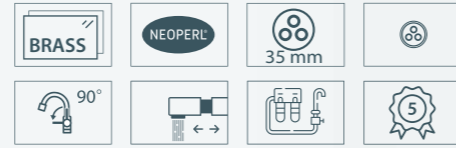
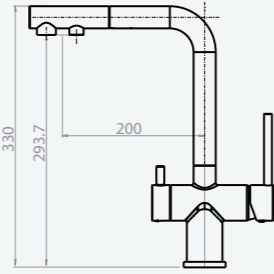

SQA102W-601 / 5383-601C



UNUS 5033

Kitchen faucet
Virtuvės maišytuvas
Küchenarmatur

Dimensions
Matmenys / Abmessungen

182 x 340 mm

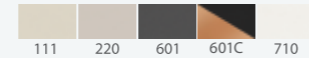
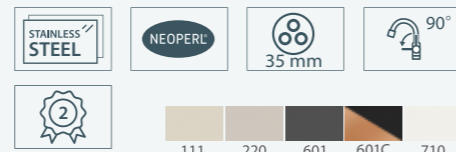
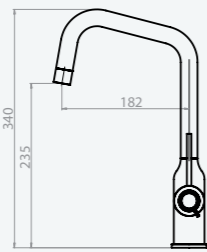

SUPRA 5383

Pull-out kitchen faucet
Virtuvės maišytuvas su ištraukiama dušo galva
Armatur mit herausziehbarem Sprühkopf

Dimensions
Matmenys / Abmessungen

215 x 310 mm

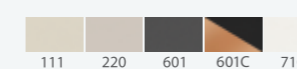
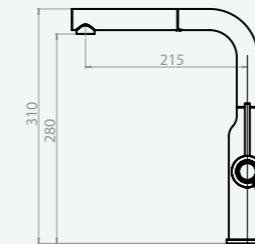

VIDE 5023

Kitchen faucet
Virtuvės maišytuvas
Küchenarmatur

Dimensions
Matmenys / Abmessungen

175 x 340 mm

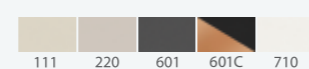
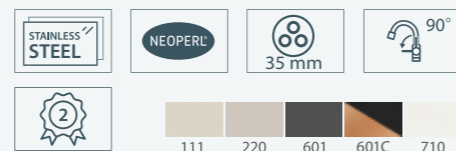
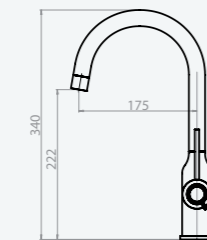

ACCESSORIES

AKSESUARAI / ZUBEHÖR

With **HELIKA®** accessories, you can customise your kitchen with a variety of colours and finishes. PAIR and MATCH various accessories of different colours and create a stunning contrast in your sink area. Whether you prefer gold, copper, or bronze, **HELIKA®** accessories will add a touch of elegance and sparkle to your kitchen.

Atraskite spalvų ir medžiagų įvairovę kartu su **HELIKA®** aksesuarais. Sujunkite ir naudokite skirtingų spalvų plautuvės aksesuarus ir kurkite nuostabiai kontrastingus derinius savo virtuvėje. Rinkitės aukso, vario ar bronzos **HELIKA®** aksesuarus ir suteikite elegancijos savo plautuvei!

Mit dem **HELIKA®**-Zubehör können Sie Ihre Küche mit einer Vielzahl von Farben und Oberflächen individuell gestalten. Kombinieren Sie verschiedene Accessoires in unterschiedlichen Farben und schaffen Sie so atemberaubende Akzente in Ihrem Spülbereich. Ob Sie nun Gold, Kupfer oder Bronze bevorzugen, **HELIKA®**-Zubehör verleiht Ihrer Küche einen Hauch von Eleganz und Glanz.

HELIKA®
Inspired by slow living



COLOURS SPALVOS / FARBEN

Accessory colours
Aksesuarų spalvos / Zubehörfarben

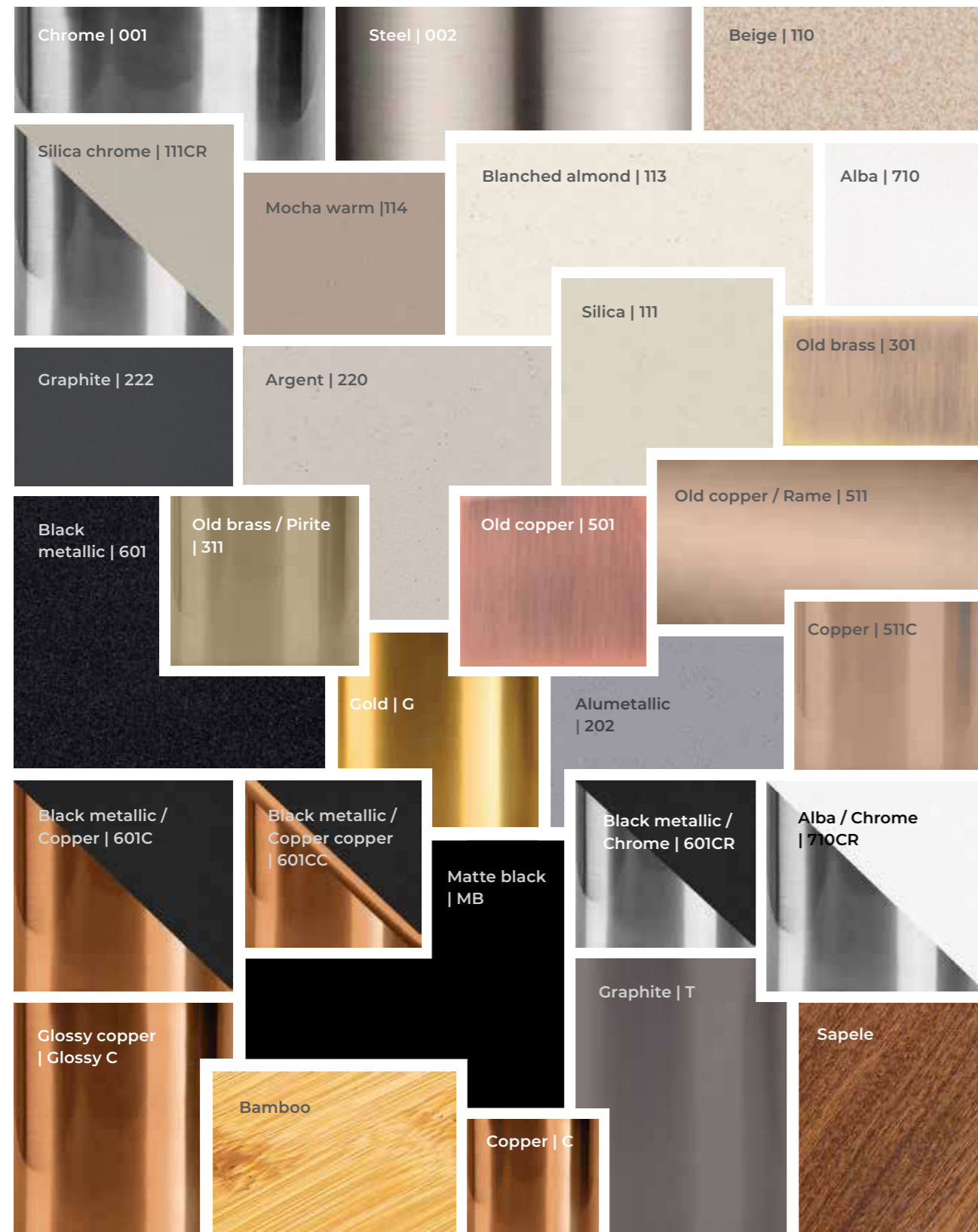

ACCESSORIES AKSESUARAI / ZUBEHÖR

SYMBOLS / SIMBOLIAI / SYMBOLE



Brass material
Žalvaris
Messing



Stainless steel material
Nerūdijantis plienas
Edelstahl



Plastic material
Plastikas
Kunststoff



Wood material
Medis
Holz



Silicone material
Silikonas
Silikon



Round overflow
Apvalus persipylimas
Runder Überlauf



Rectangular overflow
Stačiakampio formos persipylimas
Rechteckiger Überlauf



Square overflow
Kvadrato formos persipylimas
Quadratischer Überlauf



Round hollow overflow
Apvalus persipylimas su skylutėmis
Runder Überlauf mit Löchern



Manual basket strainer
Ventilis, uždaromas ranka
Manueller Siebkorb



Pop-up basket strainer
Automatinis ventilis, pasukant rankenėlę
Siebkorb mit Drehknopf



Push-button strainer
Automatinis ventilis, paspaudžiant rankenėlę
Siebkorb mit Druckknopf



2-year warranty
2 metų garantija
2 Jahre Garantie

ROLL-UP DISH DRYING RACK
INDŲ DŽIOVINIMO KILIMĖLIS
AUFROLLBARE ABTROPFMATTE

RM-3545

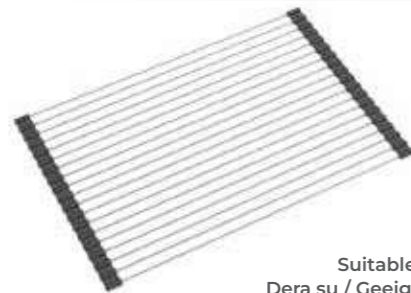

Dimensions
Matmenys
Abmessungen

350 x 450 mm



Suitable with /
Dera su / Geeignet für



SQT151, SQT103, SQL101, SQL151, SQL201, SQA100, SQA101, SQA102, SQA220, SQA230, AIR100M, DER100X, DER100L, LUN100M, LUN100N-RJL, LUN101M-RJL, LUN151N-RJL, LUN151M-RJL, ENNA sinks

ROLL-UP DISH DRYING RACK
INDŲ DŽIOVINIMO KILIMĖLIS
AUFROLLBARE ABTROPFMATTE

RM-3549

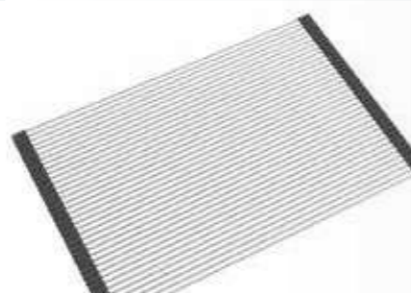

Dimensions
Matmenys
Abmessungen

350 x 490 mm



Suitable with /
Dera su / Geeignet für



SQT102, SQT101, SQT150, SQT151, SQT105, SQT104, SQT103, SQM200, SQA200 sinks

NEW

ROLL-UP DISH DRYING RACK
INDŲ DŽIOVINIMO KILIMĖLIS
AUFROLLBARE ABTROPFMATTE

RM-2845



Dimensions
Matmenys
Abmessungen

285 x 450 mm



Suitable with /
Dera su /
Geeignet für
TERRA and
NOVA sinks



COLANDER
NUVARVĖJIMO INDAS PLAUTUVEI
ABTROPFSCHALE

CL-187.360



Dimensions
Matmenys
Abmessungen

360 x 190 x 110 mm



Suitable with /
Dera su / Geeignet für



SQT100, SQT102, SQT101, SQT103, SQT150, SQT151, SQL151, SQL201, SQB101, SQB102, SQQ100, SQM200

COLANDER
NUVARVĖJIMO INDAS PLAUTUVEI
ABTROPFSCHALE

CL-187.440



Dimensions
Matmenys
Abmessungen

440 x 190 x 130 mm



Suitable with /
Dera su / Geeignet für



SQL101, SQM200, AIRA, DERA, LUNA, ENNA sinks



LUN151M-L / 7723-002 / AQF-005V /
CL-187.440 / RM-3545



SQT101AW-601 / 7783-601 / AQF-002V /
SQT-472.320-SAPELE

SILICONE TRIVET
SILIKONINIAI PADĖKLIUKAI
KÜCHENUNTERSETZER

ST



Dimensions
Matmenys
Abmessungen

Ø 200 mm



601 710

STAINLESS STEEL GRID
NERŪDIJANČIO PLIENO GROTELĖS
BODENGITTER AUS EDELSTAHL

NOTUS



Dimensions
Matmenys
Abmessungen

349 x 279 mm



Suitable with /
Dera su / Geeignet für
SQ101, SQ102

002

STAINLESS STEEL GRID
NERŪDIJANČIO PLIENO GROTELĖS
BODENGITTER AUS EDELSTAHL

CLARUS

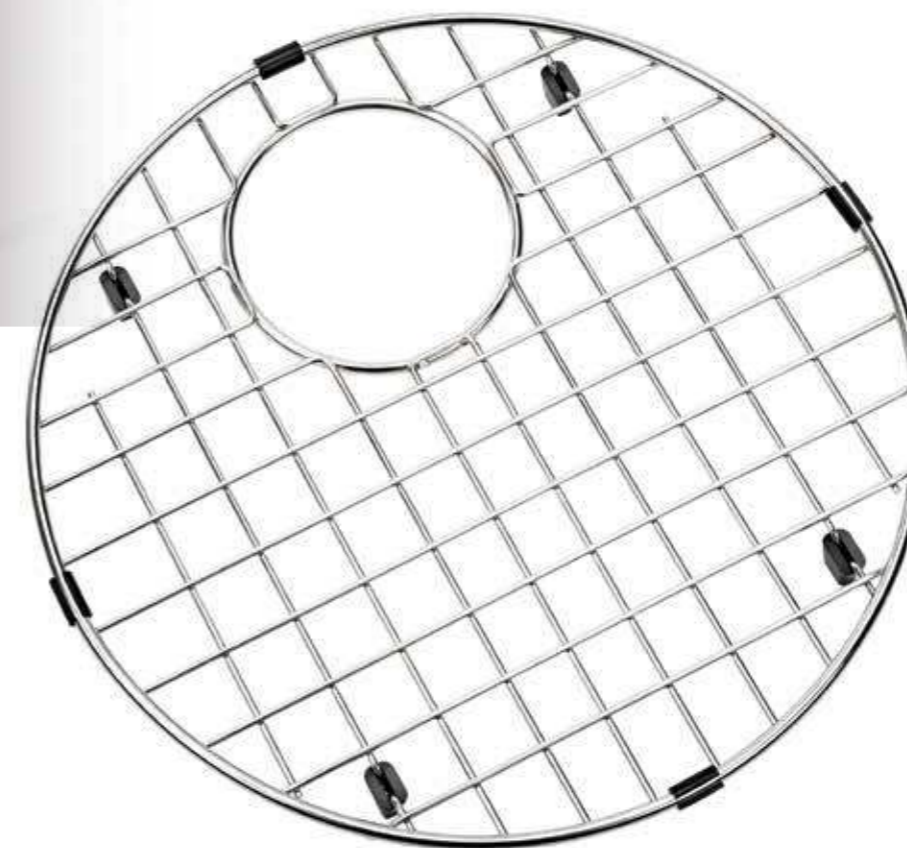

Dimensions
Matmenys
Abmessungen

Ø 353 mm

Suitable with /
Dera su /
Geeignet für
SR100, SR101, SR102



002

CHOPPING BOARD
PJAUSTYMO LENTELĖ
SCHNEIDEBRETT

SR-416.300



Dimensions
Matmenys
Abmessungen

416 x 300 mm



Suitable with /
Dera su / Geeignet für
SR100, SR102

Bamboo Sapele

CHOPPING BOARD
PJAUSTYMO LENTELĖ
SCHNEIDEBRETT

SQ-418.300



Dimensions
Matmenys
Abmessungen

418 x 300 mm



Suitable with /
Dera su / Geeignet für
SQ101, SQ102

Bamboo Sapele

CHOPPING BOARD
PJAUSTYMO LENTELĖ
SCHNEIDEBRETT

SQQ-362.300



Dimensions
Matmenys
Abmessungen

362 x 300 mm



Suitable with /
Dera su / Geeignet für
SQ100

Bamboo Sapele

CHOPPING BOARD
PJAUSTYMO LENTELĖ
SCHNEIDEBRETT

SQT-472.320



Dimensions
Matmenys
Abmessungen

472 x 320 mm



Suitable with /
Dera su / Geeignet für
SQT101, SQT102, SQT150,
SQT151SQT103, SQT104, SQT105

Bamboo Sapele

STAINLESS STEEL GRID
NERŪDIJANČIO PLIENO GROTELĖS
BODENGITTER AUS EDELSTAHL

DIAMANTO

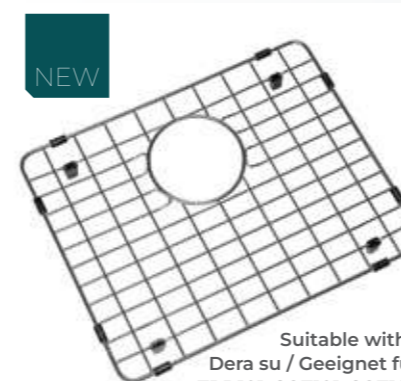

Dimensions
Matmenys
Abmessungen

392 x 311 mm



Suitable with /
Dera su / Geeignet für
TPD101, SQT101, SQT102

002

STAINLESS STEEL GRID
NERŪDIJANČIO PLIENO GROTELĖS
BODENGITTER AUS EDELSTAHL

QUADRO

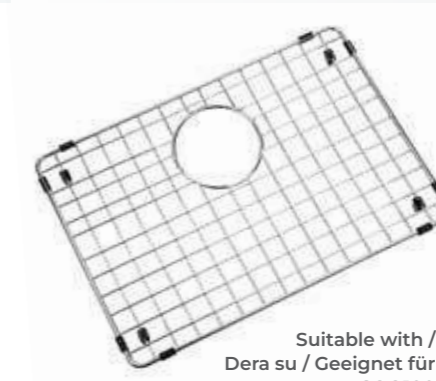

Dimensions
Matmenys
Abmessungen

451 x 316 mm



Suitable with /
Dera su / Geeignet für
SQ100

002



Soap dispenser / Dozatoriai / Seifenspender

NEW



DTQ

Soap dispenser
Dozatorius
Seifenspender

Material:
Brass + plastic bottle, 350 ml
Žalvaris + plastikinis buteliukas, 350 ml
Messing + Kunststoffflasche, 350 ml

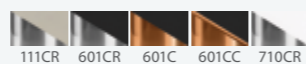
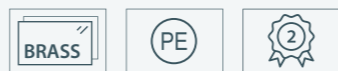

DTR

Soap dispenser
Dozatorius
Seifenspender

Material:
Brass + plastic bottle, 350 ml
Žalvaris + plastikinis buteliukas, 350 ml
Messing + Kunststoffflasche, 350 ml

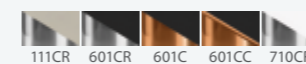

NEW



DQ

Soap dispenser
Dozatorius
Seifenspender

Material:
Brass + plastic bottle, 350 ml
Žalvaris + plastikinis buteliukas, 350 ml
Messing + Kunststoffflasche, 350 ml

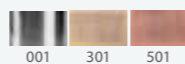

DR

Soap dispenser
Dozatorius
Seifenspender

Material:
Brass + plastic bottle, 350 ml
Žalvaris + plastikinis buteliukas, 350 ml
Messing + Kunststoffflasche, 350 ml

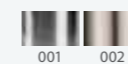

NEW



DH

Soap dispenser
Dozatorius
Seifenspender

Material:
Brass + plastic bottle, 350 ml
Žalvaris + plastikinis buteliukas, 350 ml
Messing + Kunststoffflasche, 350 ml



SQT100W-601 / 5523-601 / AQP-601 / D-601



DS

Soap dispenser
Dozatorius
Seifenspender

Material:
Stainless steel + plastic bottle, 500 ml
Nerūdijantis plienas + plastikinis buteliukas, 500 ml
Edelstahl + Kunststoffflasche, 500 ml



DL

Soap dispenser
Dozatorius
Seifenspender

Material:
Brass + plastic bottle, 350 ml
Žalvaris + plastikinis buteliukas, 350 ml
Messing + Kunststoffflasche, 350 ml

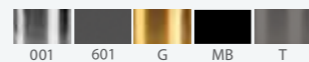

D

Soap dispenser
Dozatorius
Seifenspender

Material:
Brass + plastic bottle, 350 ml
Žalvaris + plastikinis buteliukas, 350 ml
Messing + Kunststoffflasche, 350 ml

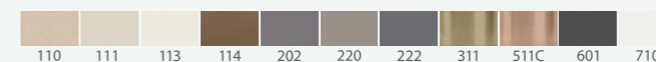
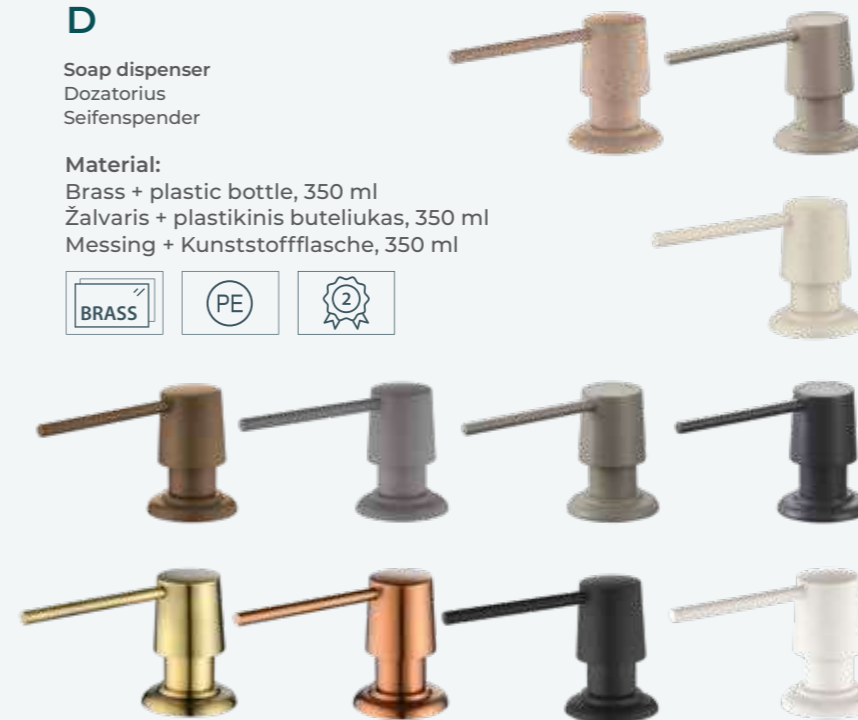

D

Soap dispenser
Dozatorius
Seifenspender

Material:
Stainless steel + plastic bottle, 500 ml
Nerūdijantis plienas + plastikinis buteliukas, 500 ml
Edelstahl + Kunststoffflasche, 500 ml





Strainers / Ventiliai / Siebkörbe

MANUAL BASKET STRAINER
RANKINIS VENTILIS
MANUELLER SIEBKORB

AQF-001V

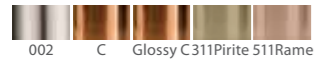

POP-UP BASKET STRAINER
AUTOMATINIS PASUKAMAS VENTILIS
POP-UP-SIEBKORB

AQF-002V

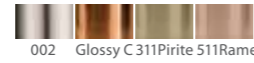

MANUAL BASKET STRAINER
RANKINIS VENTILIS
MANUELLER SIEBKORB

AQF-009V



MANUAL BASKET STRAINER
RANKINIS VENTILIS
MANUELLER SIEBKORB

AQF-001V-GJT



POP-UP BASKET STRAINER
AUTOMATINIS PASUKAMAS VENTILIS
POP-UP-SIEBKORB

AQF-003V

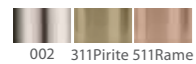

MANUAL BASKET STRAINER
RANKINIS VENTILIS
MANUELLER SIEBKORB

AQF-005V



PUSH-BUTTON STRAINER
AUTOMATINIS PASPAUDŽIAMAS VENTILIS
SIEBKORB MIT DRUCKKNOPF

AQL-002V



PUSH-BUTTON STRAINER
AUTOMATINIS PASPAUDŽIAMAS VENTILIS
SIEBKORB MIT DRUCKKNOPF

AQL-003V



MANUAL BASKET STRAINER
RANKINIS VENTILIS
MANUELLER SIEBKORB

AQ-001H

NEW



002

POP-UP BASKET STRAINER
AUTOMATINIS PASUKAMAS VENTILIS
POP-UP-SIEBKORB

AQ-002H

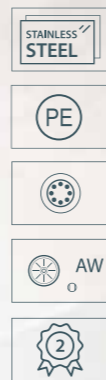

002

POP-UP BASKET STRAINER
AUTOMATINIS PASUKAMAS VENTILIS
POP-UP-SIEBKORB

AQ-004H



002

MANUAL BASKET STRAINER
RANKINIS VENTILIS
MANUELLER SIEBKORB

AQ-005H

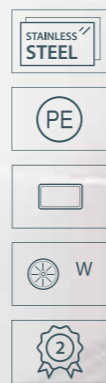

002

POP-UP BASKET STRAINER
AUTOMATINIS PASUKAMAS VENTILIS
POP-UP-SIEBKORB

AQ-006H



002

POP-UP BASKET STRAINER
AUTOMATINIS PASUKAMAS VENTILIS
POP-UP-SIEBKORB

AQ-007H

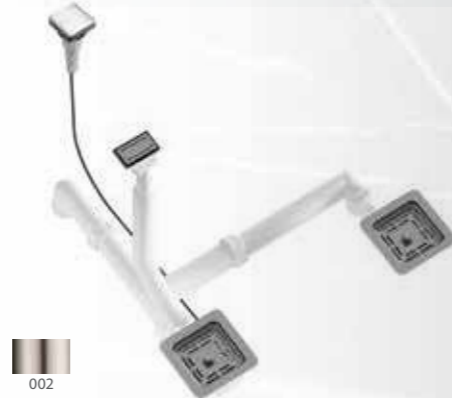

002

MANUAL BASKET STRAINER
RANKINIS VENTILIS
MANUELLER SIEBKORB

AQ-008H



002

MANUAL BASKET STRAINER
RANKINIS VENTILIS
MANUELLER SIEBKORB

AQP



111 113 220 601 710

SIPHON
SIFONAS
SIPHON

AQ-T1



SIPHON
SIFONAS
SIPHON

AQ-T3



TQL100W-601 / 7723-601 / AQP-601

CLEANING AND CARE PRODUCTS

VALYMO IR PRIEŽIŪROS PRIEMONĖS
REINIGUNGS - UND PFLEGEPRODUKTE

CARE

HELIKA CARE - granite surface cleaner and polisher.

HELIKA CARE – granitinių paviršių valiklis ir blizgiklis.

HELIKA CARE - Reiniger und Politur für Granitoberflächen.

LIME

HELIKA LIME - granite and gelcoat surface limescale remover.

HELIKA LIME – granitinių ir gelkauto paviršių kalkių valiklis.

HELIKA LIME - Kalkentferner für Granitoberflächen.

SHINE

HELIKA SHINE - stainless steel surface cleaner and polisher.

HELIKA SHINE – nerūdijančio plieno valiklis ir blizgiklis.

HELIKA SHINE - Reiniger und Politur für Edelstahloberflächen.

© HELIKA®



Make your sink sparkle and shine!

45 cm

ECO1



ø 450 mm

ECO2



620 x 440 mm

ECO3



760 x 440 mm

SIMPLEX SQS100



425 x 500 mm

NOVA SQN100



460 x 515 mm

NOTUS SQ101



765 x 460 mm

NOTUS SQ102



575 x 460 mm

CLARUS SR100



ø 505 mm

45 cm

ARCA SQA100



380 x 380 mm

50 cm

ARCA SQA101



420 x 460 mm

50 cm

TESA SQT102



620 x 500 mm

TESA SQT101



780 x 500 mm

TESA SQT100



490 x 510 mm

ONDO MP100



780 x 500 mm

CLARUS SR102



580 x 470 mm

CLARUS SR101



780 x 500 mm

BELLA SQB101



780 x 500 mm

BELLA SQB102



670 x 500 mm

60 cm

DELICIA SQD100



555 x 455 mm

TESA SQT150



580 x 500 mm

TESA SQT151



800 x 500 mm

TESA PLUS SQT105



780 x 500 mm

TESA PLUS SQT104



860 x 500 mm

TESA PLUS SQT103



1000 x 500 mm

QUADRO SQQ100



565 x 510 mm

NEW QUADRO SQU100



560 x 500 mm

60 cm

NEW KOPA SQK100



570 x 510 mm

NEW KOPA SQK103



1000 x 500 mm

NEW KOPA SQK151



1000 x 500 mm

ECO4



760 x 440 mm

LIRA SQL101



780 x 500 mm

LIRA SQL151



960 x 500 mm

NEW DIAMANTO TPD101



780 x 500 mm

70 cm

ARCA SQA102



585 x 460 mm

ARCA SQA103



585 x 535 mm

80 cm

NEW QUADRO SQQ103



795 x 505 mm

DELICIA SQD101



740 x 455 mm

DELICIA SQD150



650 x 455 mm

DELICIA PLIUS GQD150B



860 x 540 mm

DELICIA PLIUS GQD150W



860 x 540 mm

PAPILLON SCP151



945 x 505 mm

90 cm

ARCA SQA230R|L



810 x 480 mm

ARCA SQA104



810 x 480 mm

ARCA SQA200



810 x 480 mm

ARCA SQA210



840 x 560 mm

ARCA SQA220



810 x 520 mm

MAGNA SQM200



860 x 510 mm

NEW LARGUS TQL100



840 x 560 mm

VILLA PREMIUM GQV100



838 x 508 mm

30 cm

ENNA ENN100S



212 x 350 mm

50 cm

ENNA ENN100X



450 x 450 mm

NOVA100X



450 x 450 mm

50 cm

DERA DER100X-T



450 x 450 mm

LUNA LUN100X



450 x 505 mm

50 cm

AIRA AIR100X-G



450 x 510 mm

AIRA AIR100X-C



450 x 510 mm

60 cm

DERA DER100L



550 x 450 mm

DERA DER100L-C



550 x 450 mm

60 cm

TERRA100N-T



550 x 505 mm

AIRA AIR100N



550 x 510 mm

60 cm

ENNA ENG100XB-LJR

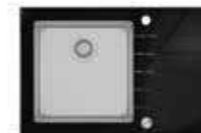

780 x 500 mm
STAINLESS STEEL AND
TEMPERED GLASS SINK

70 cm

ENNA ENN100L



590 x 450 mm

NOVA100L



590 x 450 mm

80 cm

LUNA LUN100M



790 x 505 mm

TERRA100M



790 x 505 mm

80 cm

AIRA AIR100M-T



790 x 510 mm

45 cm

ENNA ENN100M



390 x 450 mm

NOVA100X-C



450 x 450 mm

NOVA100X-G



450 x 450 mm

NOVA100X-T



450 x 450 mm

DERA DER100X



450 x 450 mm

DERA DER100X-C



450 x 450 mm

DERA DER100X-G



450 x 450 mm

TERRA100X



450 x 505 mm

TERRA100X-C



450 x 505 mm

TERRA100X-G



450 x 505 mm

TERRA100X-T



450 x 505 mm

AIRA AIR100X



450 x 510 mm

AIRA AIR100X-T



450 x 510 mm

LUNA LUN101N-RJL



780 x 500 mm

TERRA101N-LJR



780 x 500 mm

TERRA101N-LJR-C



780 x 500 mm

TERRA101N-LJR-G



780 x 500 mm

TERRA101N-LJR-T



780 x 500 mm

DERA DER100L-G



550 x 450 mm

DERA DER100L-T



550 x 450 mm

LUNA LUN100N



550 x 505 mm

TERRA100N



550 x 505 mm

TERRA100N-C



550 x 505 mm

TERRA100N-G



550 x 505 mm

AIRA AIR100N-C



550 x 510 mm

AIRA AIR100N-G



550 x 510 mm

AIRA AIR100N-T



550 x 510 mm

LUNA LUN151N-RJL



780 x 500 mm

LUNA LUN151M-RJL



1000 x 510 mm

LUNA LUN101M-RJL



1000 x 510 mm

NOVA100L

NOVA100L-C



590 x 450 mm

NOVA100L-G



590 x 450 mm

NOVA100L-T



590 x 450 mm

TERRA100M

TERRA100M-C



790 x 505 mm

TERRA100M-G



790 x 505 mm

TERRA100M-T



790 x 505 mm

AIRA AIR100M



790 x 510 mm

AIRA AIR100M-C



790 x 510 mm

AIRA AIR100M-G



790 x 510 mm

90 cm

ENNA ENN200L



760 x 450 mm

ENNA ENN100B



790 x 450 mm



CAST MARBLE WASHBASINS

GELKAUTO PRAUSTUVAI / WASHBECKEN AUS MINERALGUSS

For over 20 years, we have been producing high-quality kitchen and bathroom products that meet the needs and expectations of our customers. Now, we are proud to introduce our new brand, **TURTL®**, which offers a unique blend of elegance and durability in the bathroom. **TURTL®** features washbasins made of cast marble, a modern material that creates a smooth and luxurious surface. With **TURTL®**, you can enjoy the beauty and comfort of a premium washbasin experience.

Jau daugiau nei 20 metų gaminame aukštos kokybės granitinius virtuvės ir vonios gaminius, atitinkančius klientų poreikius ir lūkesčius. Dabar didžiuojamės galėdami pristatyti naują prekių ženklą **TURTL®**, kuris vonios kambaryje siūlo unikalų elegancijos ir ilgaamžiškumo derinį. **TURTL®** praustuvasi pagaminti iš gelkauto ir kompozicinio marmuro – modernios medžiagos, kuri sukuria lygų ir prabangų paviršių. Naudodami **TURTL®** mėgausitės aukščiausios kokybės praustuvų grožiu ir komfortu.

Seit über 20 Jahren produzieren wir hochwertige Küchen- und Badprodukte, die den Bedürfnissen und Erwartungen unserer Kunden gerecht werden. Jetzt sind wir stolz, Ihnen unsere neue Marke **TURTL®** vorzustellen, die eine einzigartige Mischung aus Eleganz und Langlebigkeit im Badezimmer bietet. **TURTL®** bietet Waschbecken aus Mineralguss, einem modernen Material, das eine glatte und luxuriöse Oberfläche schafft. Mit **TURTL®** können Sie die Schönheit und den Komfort eines Premium-Waschbeckens genießen.



CAST MARBLE SURFACE
GELKAUTO PAVIRŠIUS
MINERALGUSS



COMPOSITE MARBLE
KOMPOZITINIS MARMURAS
VERBUNDMARMOR



HYGIENIC
HIGIENIŠKAS
HYGIENISH



GLOSSY SURFACE
BLIZGUS PAVIRŠIUS
HOCHGLANZFINISH



EASY MAINTENANCE
LENGVA PRIEŽIŪRA
PFLEGELEICHT



EASY DRAIN
LENGVAS NUTEKĖJIMAS
GUT ABLAUFEND

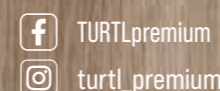

TURTLpremium

turtl_premium



5-year
warranty



Made
in EU



Tested by
EN 14688:2015+A1:2018





EN
LT
DE

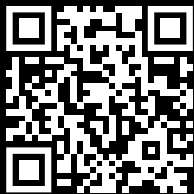

helika-sinks.com

 **HELIKA**[®]

Compotexa, UAB
Phone: +370 37 451 823 | Taikos pr. 88A, LT-51183 Kaunas, Lithuania
info@compotexa.com